

BEIER Variator®

BEIER-CYCLO Variator®

A Type

B Type

D Type (ND Series)

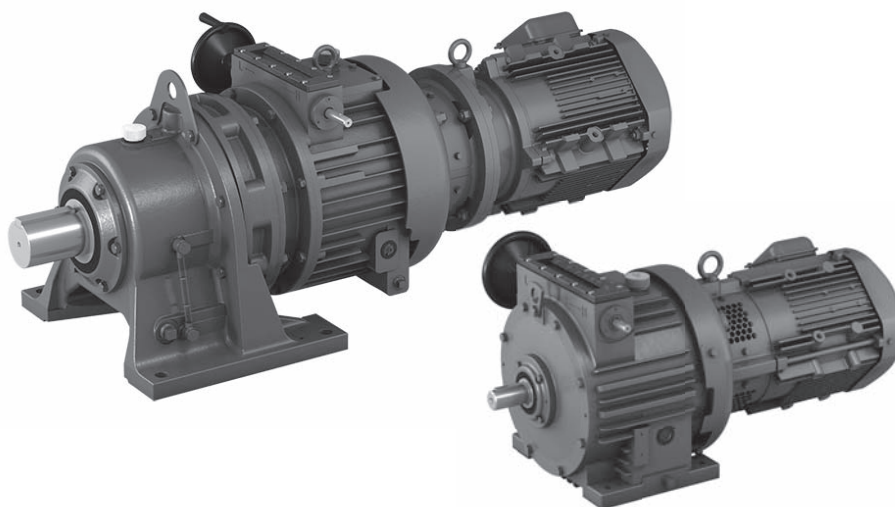

《CAUTION》

- These Products should be handled, installed and maintained by trained technicians.
Carefully read the maintenance manual before use.
- A copy of this maintenance manual should be sent to the actual user.
- This maintenance manual should be kept by the user for future reference.

Safety and Other Precautions

- Carefully read this maintenance manual and all accompanying documents before use (installation, operation, maintenance, inspection, etc.). Thoroughly understand the machine, information about safety, and all precautions for correct operation. Retain this manual for future reference.
- Pay close attention to the "DANGER" and "CAUTION" warnings regarding safety and proper use.



: Improper handling may result in physical damage, serious personal injury and/or death.



: Improper handling may result in physical damage and/or personal injury.

Matters described in  **CAUTION** may lead to serious danger depending on the situation. Be sure to observe important matters described herein.



DANGER

- Transport, installation, plumbing, wiring, operation, maintenance, and inspections should be performed by trained technicians; otherwise, electric shock, injury, fire, or damage to the equipment may result.
- When using the equipment in conjunction with **an explosion proof motor**, a technician with electrical expertise should supervise the transport, installation, plumbing, wiring, operation, maintenance and inspection of the equipment so as to avoid a potentially hazardous, situation that may result in electrical shock, fire, explosion, personal injury and/or damage to the equipment.
- When the unit is to be used in a system for human transport, a secondary safety device should be installed to minimize chances of accidents resulting in personal injury, death, or damage to the equipment.
- When the unit is to be used for an elevator, install a safety device on the elevator side to prevent it from falling; otherwise, personal injury, death, or damage to the equipment may result.

How to Refer to the Maintenance Manual

● This maintenance manual is common for both BEIER Variator and BEIER-CYCLO Variator. The symbols shown below appear in the upper right corner of each page to indicate the classification. Read the applicable pages. On **COMMON** pages, these symbols identify distinctions between with motor and without motor.

• Refer to the motor maintenance manual (Cat. No. MM1001E) for the handling of motor with a brake.

Specifications		Common specifications	Basic type Beier variator	Beier variator with built-in gear type	Beier Cyclo variator
Symbol	with motor	COMMON			
	without motor				

CONTENTS

1. Inspection Upon Delivery	3
2. Storage	7
3. Transport	7
4. Installation	8
5. Coupling with Other Machines	9
6. Wiring 	11
7. Operation	15
8. Daily Inspection and Maintenance	16
9. Lubricating Oil Cooling Device	26
10. Remote Control Equipment	31
11. Troubleshooting	28
12. Construction Drawings	32
13. Warranty	36

1. Inspection Upon Delivery

⚠ CAUTION

- Unpack the unit after verifying that it is positioned right side up; otherwise, injury may result.
- Verify that the unit received is in fact the one you ordered. Installing the wrong unit may result in personal injury or equipment damage.
- Do not remove the rating plate.

Verify the items listed below upon receiving the Beier Variator. If a nonconformity or problem is found, contact our nearest agent, distributor, or sales office.

- (1) Does the information on the rating plate conform to what you ordered?
- (2) Was there any part broken during transport?
- (3) Are all bolts and nuts tightened firmly?

1-1) How to Refer to the Rating Plate

• When making an inquiry, advice us of the model name, Serial no.

Beier Variator Basic type, With Built-in gear type

(1) Beier **COMMON**

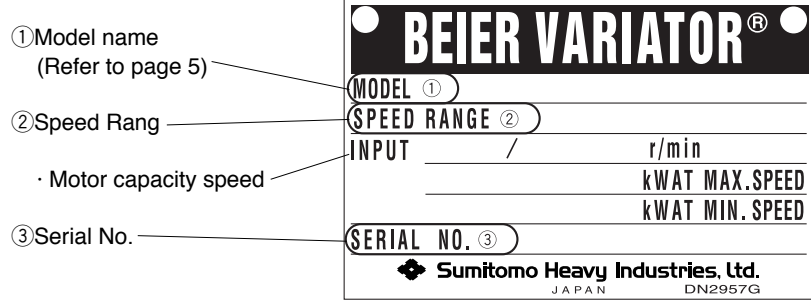

Fig.1 Rating Plates of Beier Variator Basic type, or with Built-in gear type

(2) Motor

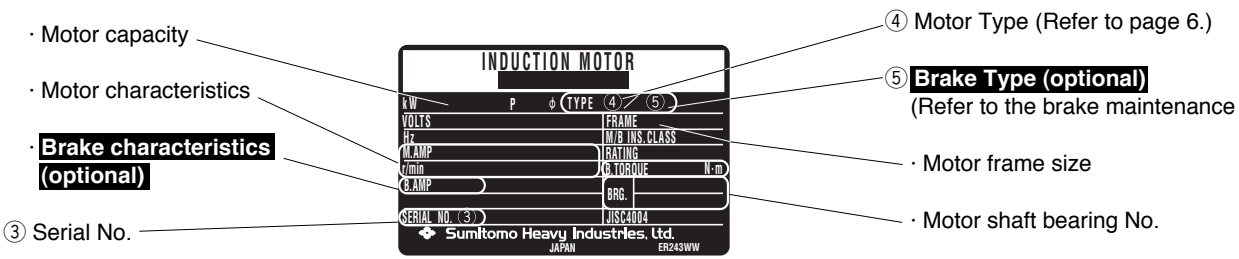

Fig.2 Motor Rating Plate

Beier Cyclo Variator

(1) Beier Cyclo **COMMON**

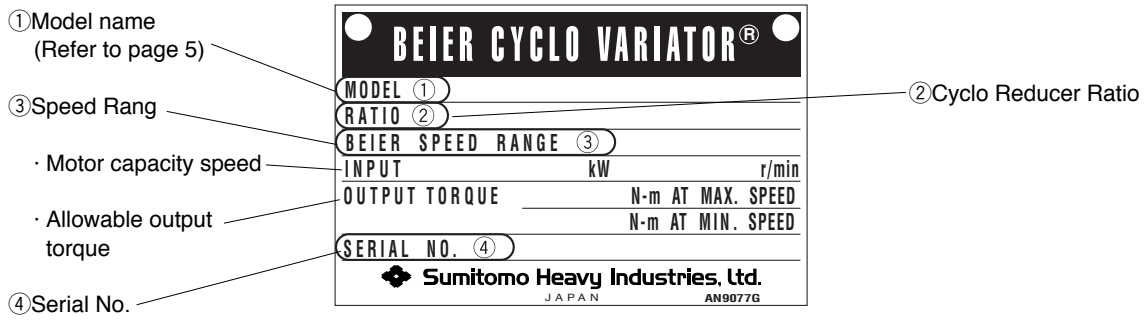

Fig.3 Rating Plates of Beier-Cyclo Variator

(2) Motor



Same as page 3.

1-2) Lubrication Method **COMMON**

Refer to "8-2. Confirmation of Lubrication Method" on page 17 to confirm the lubrication method.

- **Oil-lubricated** models are shipped without oil. Units must be filled with the proper amount of recommended oil prior to start-up.

1-3) Type of Variator

Respective codes and motor nomenclature are shown below. Please verify that the type you received conforms to what you ordered.

BEIER Variator (Basic Type)

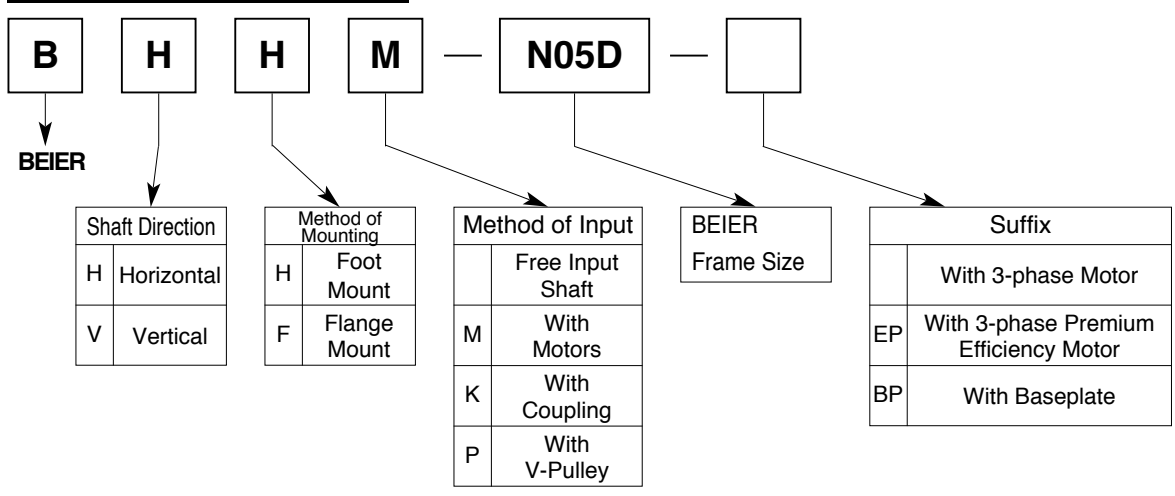

BEIER Variator (Built-in Gear Type)

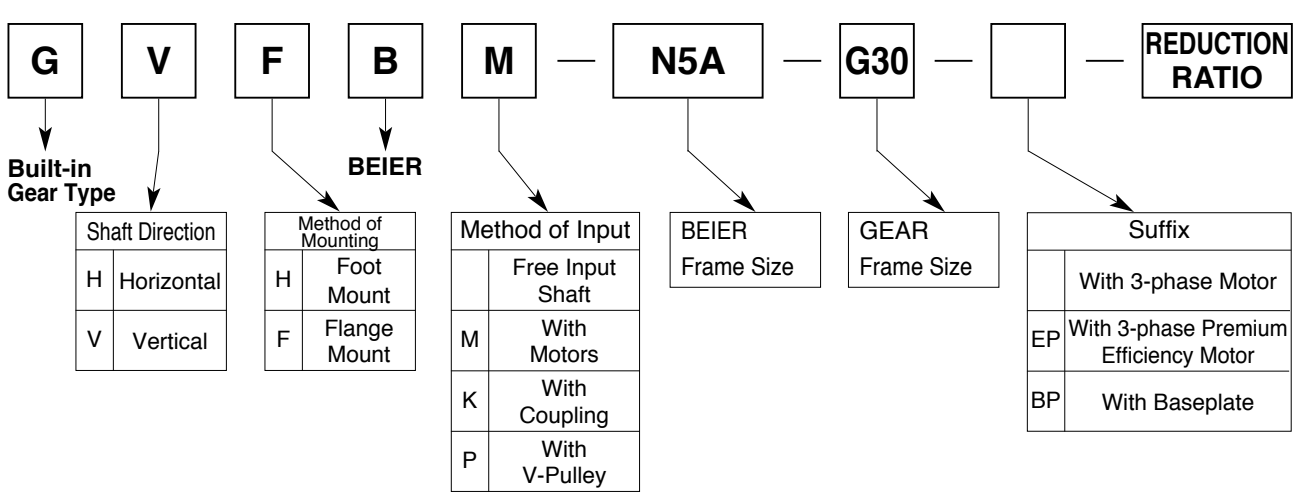

BEIER-CYCLO Variator

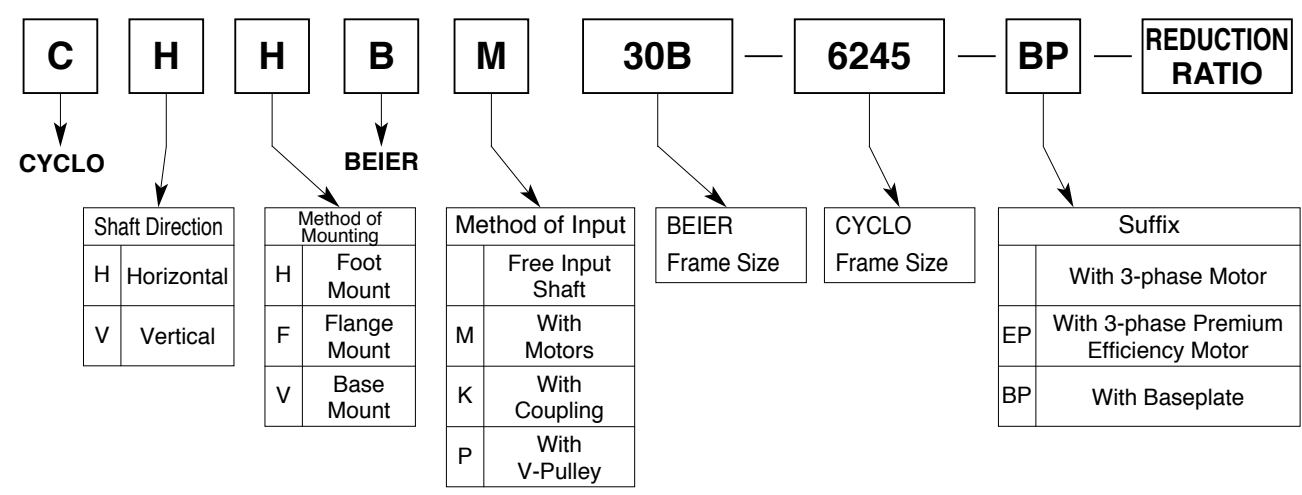

1-4) Type of Motor 

Respective codes and motor nomenclature are shown below. Please verify that the type you received conforms to what you ordered.

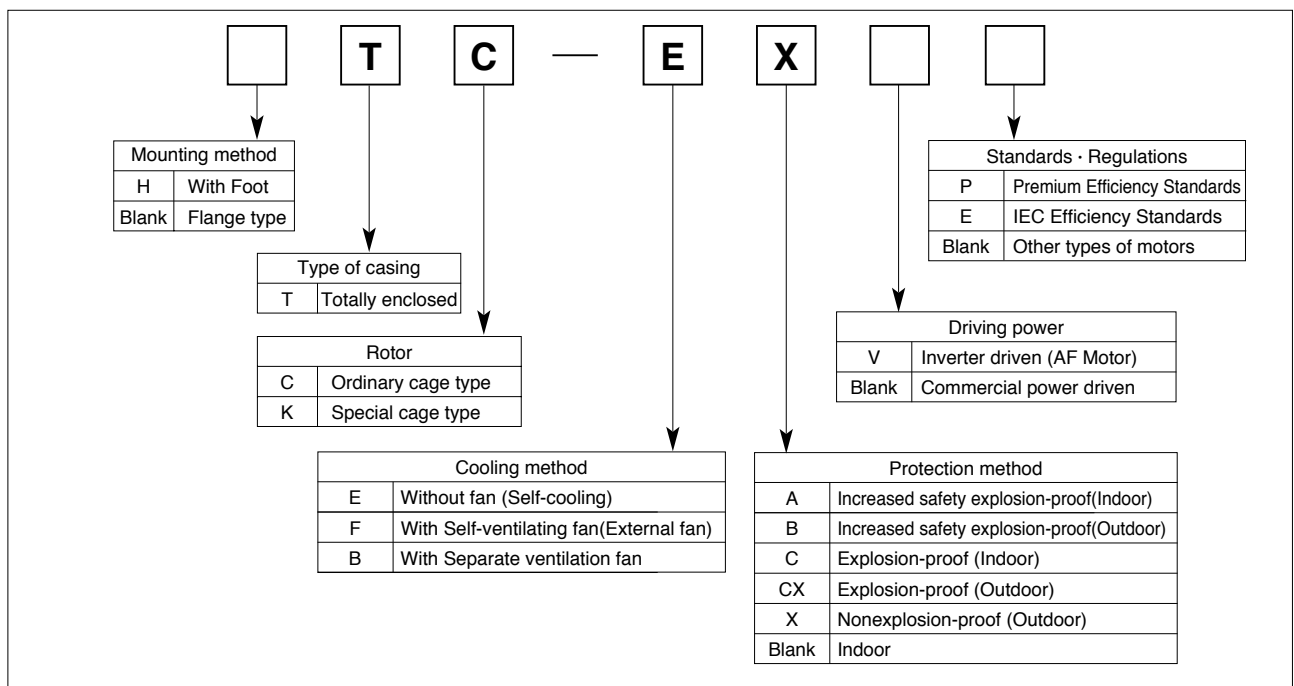

2. Storage

When storing Beier variators for any extended period of time, consider the following important points :

2-1) Storage Location

Store the unit in a clean, dry place indoors.

- Avoid storage outdoors or in places with humidity, dust, sudden temperature changes or corrosive gas.

2-2) Storage Period

- (1) Storage period should be less than the "Rust-Proofing period" listed below.
- (2) When the storage period exceeds the standard "rust-proofing period", special rust-proofing is necessary. Contact the factory for details.
- (3) Export models need export rust prevention. Contact the factory for details.
- (4) Standard rust-proofing specification :
 - ① Outside rust-proofing
Before shipment, rust-proofing treatment is administered. Check the effect of rust-proofing, whenever necessary it should be administered.
 - ② Inside rust-proofing

Table 1

Lubrication	Grease lubricated models	Oil lubricated models
Rust-proofing period	1 Year	6 Months
Storage condition	Generally to be stored inside the shop or warehouse, relatively free of humidity, dust, extreme temperature fluctuation, corrosive gas and similar atmosphere.	

2-3) Use After Storage

- (1) Oil seals will deteriorate when exposed to high temperatures and UV rays. Inspect the oil seals before operation.
Replace the oil seals after long-term storage if there is any sign of deterioration.
- (2) After starting the Beier, verify that there is no abnormal sound, vibration, or heat rise. If supplied as a brakemotor, check that the brake operates properly. If any anomaly is observed, contact our nearest agent, distributor, or sales office.

3. Transport

⚠ DANGER

- Do not stand directly under a unit suspended by a crane or other lifting mechanism; otherwise, injury or death may result.

⚠ CAUTION

- Exercise ample care so as not to drop the unit. When a hanging bolt or hole is provided, be sure to use it. After mounting a Beier unit to the equipment, do not hoist the entire machine using the hanging bolt or hole; otherwise, personal injury or damage to the equipment and/or lifting device may result.
- Before hoisting, refer to the rating plate, crate, outline drawing, catalog, etc. for the weight of the unit. Never hoist a unit that exceeds the rating of the crane or other mechanism being used to lift it; otherwise, personal injury or damage to the equipment and/or lifting device may result.

4. Installation

⚠ DANGER

- Do not use a standard unit in an explosive atmosphere (which is likely to be filled with explosive gas or steam). Under such conditions, an explosion-proof motor should be used; otherwise, electric shock, personal injury, explosion fire, or damage to the equipment may result.
- Since the inverter itself is not explosion-proof, install an **inverter-driven, explosion-proof type motor** in a place free from explosive gas; otherwise, electric shock, personal injury, explosion fire, or damage to the equipment may result.

⚠ CAUTION

- Do not use the Beier variator for purposes other than those shown on the rating plate or in the manufacturing specifications; otherwise, electric shock, personal injury, or damage to the equipment may result.
- Do not place flammable objects around the Beier variator; otherwise, fire may result.
- Do not place any object around the Beier variator that will hinder ventilation. Insufficient ventilation can cause excessive heat build-up that may result in burns or fire.
- Do not step on or hang from the Beier variator; otherwise injury may result.
- Do not touch the shaft end of the Beier variator, inside keyways, or the edge of the motor cooling fan with bare hands; otherwise, injury may result.
- When the unit is used in food processing applications vulnerable to oil contamination, install an oil pan or other such device to cope with oil leakage due to breakdown or failure; otherwise, oil leakage may damage products.
- Filling lubrication oil after installation.

4-1) Installation Location

- Ambient temperature : -10°C to +40°C
- Ambient humidity : 85% max.
- Altitude : 1000m max.
- Ambient atmosphere : There should be no corrosive gas, explosive gas, or steam.
The location should be well ventilated without dust.
- Installation location : Indoors, with minimum dust and no water splashing.

- Units made to special specifications are necessary for installation under conditions other than the above.
- Units made according to the outdoor, explosion-proof or other specifications can be used under the specified conditions without any problem.
- Install units where inspection, maintenance, and other such operations can be easily carried out.
- Install units on a sufficiently rigid base.

4-2) Installation Angle

Table 2 Installation Angle

Grease lubricated model	Free
Oil lubricated model	Low speed shaft Horizontal or Vertical (Refer to page 5. Contact us inclined installation.)

When the unit is made according to your specification for inclined installation, do not install it at any angle other than the specified angle. (The shaft orientation of the standard **outdoor variator** is horizontal. Contact us for other shaft orientations.)

- Do not remove the eyebolt on the motor. Should the eyebolt be removed, put a bolt into the threaded hole or take other water-proofing measures to prevent water from entering the motor through the threaded hole.

5. Coupling with Other Machines

⚠ CAUTION

- Confirm the rotation direction before coupling the unit with the driven machine. Incorrect rotation direction may cause personal injury or damage to the equipment.
- When operating the variator alone (uncoupled), remove the key that is temporarily attached to the output shaft; otherwise, injury may result.
- Cover the rotating parts; otherwise, injury may result.
- When coupling the variator with a load, check that the centering, the belt tension and parallelism of the pulleys are within the specified limits. When the unit is directly coupled with another machine, check that the direct coupling accuracy is within the specified limits. When a belt is used for coupling the unit with another machine, check the belt tension. Correctly tighten bolts on the pulley and coupling before operation; otherwise, injury may result because of misalignment.

5-1) Confirming Rotation Direction

With motor 

Figure 4 shows the rotation direction of the output shaft when wires are connected as shown in Fig.9 on page 13.

Fig.4 Rotation Direction of slow speed shaft.(with motor)

When the motor wiring conforms to Fig. 9 the motor shaft turns clockwise viewed from the opposite side of the load side. At that time, the rotation direction of slow speed shaft is in the direction of the arrow shown below.

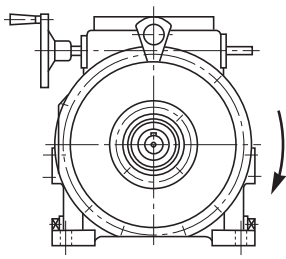
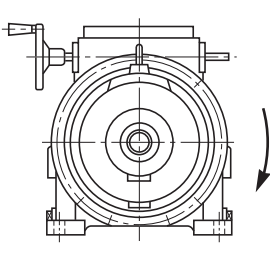
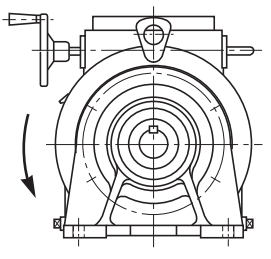
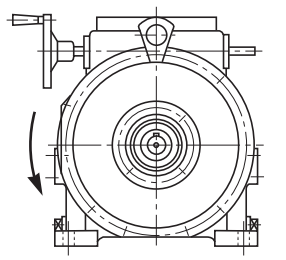
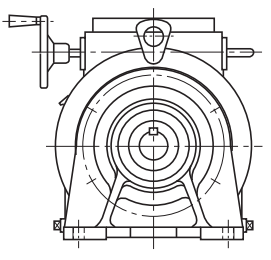
Type		Basic, Beier-Cylo (2 stages)	with Built-in Gear	Beier Cyclo (1 stage)
A/B Type	Rotation direction of slow speed shaft (Viewed from load side)			
	Rotation direction of slow speed shaft (Viewed from load side)		—————	

· For reverse rotation, change the positions of R and T of the motor wiring.

Without motor 

Table 3 Rotation Direction of slow speed shaft.(without motor)

Type		Basic, Beier-Cylo (2 stages)	with Built-in Gear	Beier Cyclo (1 stage)
A-B Type	Rotation direction of slow speed shaft	As compared with high speed shaft, opposite direction.	As compared with high speed shaft, opposite direction.	As compared with high speed shaft, same direction.
D Type	Rotation direction of slow speed shaft	As compared with high speed shaft, same direction.	—————	As compared with high speed shaft, opposite direction.

5-2) Coupling Installation

- When installing a coupling, do not impact or apply excessive thrust load to the shaft ; otherwise, the bearing may be damaged or collar may be left.
- Thermal shrinking is the recommended installation method.
- when a sprocket, gear or pulley is coupled with the variator, use within the range of the allowable radial and axial load defined on our catalog.

(1) When Using a Coupling

The accuracy of the dimensions (A, B, and X) shown in Fig.5 should be within the tolerance shown in Table 4.

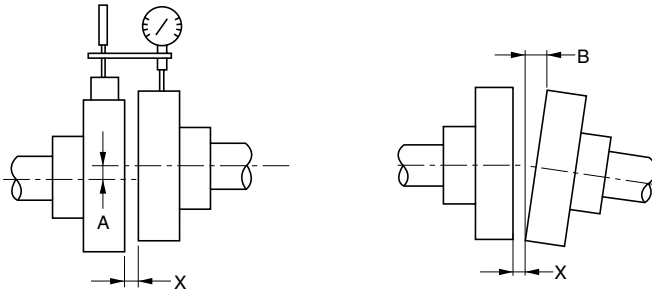

Fig. 5

Table 4 Centering Accuracy of Flexible Coupling

Dimension A Tolerance	0.1mm or manufacturer's specification
Dimension B Tolerance	0.1mm or manufacturer's specification
X dimension	Manufacturer's specification

(2) When Using a Chain Sprocket and Gear

- The chain tension angle should be perpendicular to the shaft.
- Refer to the chain catalog for the chain tension.
- Select sprockets and gears whose pitch diameter are three times the shaft diameter or greater.
- Install sprocket and gears so that their point of load application will be closer to the variator side with respect to the length of the shaft. (Fig.6)

(3) When Using a V-belt

- Excessive V-belt tension will damage the shaft and bearing. Refer to the V-belt catalog for proper tension.
- The parallelism and eccentricity (β) between two pulleys should be within $20'$. (Fig.7)
- Use a matched set with the same circumferential length when more than one belt is to be installed.
- Install V-pulley so that their point of load application will be closer to the variator side with respect to the length of the shaft.

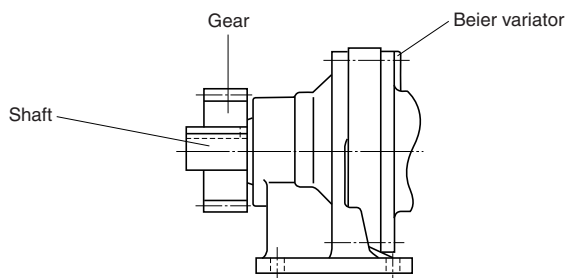

Fig. 6

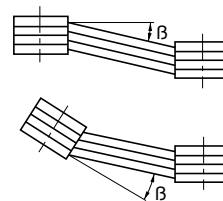

Fig. 7



6. Wiring

- Wiring for **SUMITOMO standard 3-phase motor** is shown below.
Refer to the respective instruction manual **for brakemotors** and **motors made by other companies** when they are used.

DANGER

- Do not handle the unit when cables are live. Be sure to turn off the power; otherwise, electric shock may result.
- Connect a power cable to the unit according to the diagram shown inside the terminal box or in the maintenance manual; otherwise, electric shock or fire may result.
- Do not forcibly curve, pull, or clamp the power cable and lead wires; otherwise, electric shock or fire may result.
- Correctly ground the grounding bolt; otherwise, electric shock may result.
- The lead-in condition of an **explosion-proof type motor** shall conform to the facility's electrical codes, extension regulations and explosion-proofing guide, as well as the maintenance manual; otherwise, electric shock, personal injury, explosion, fire or damage to the equipment may result.

CAUTION

- When wiring, follow the facility's electrical codes and extension regulations; otherwise, burning, electric shock, injury, or fire may result.
- The motor is not equipped with a protective device. However, it is compulsory to install an overload protector according to facility electrical codes. It is recommended to install other protective devices (earth leakage breaker, etc.), in addition to an overload protector, in order to prevent burning, electric shock, injury, and fire.
- Never touch the terminals when measuring insulation resistance; otherwise, electric shock may result.
- **When using a star-delta starter**, select one with an electromagnetic switch on the primary side (3-contact type); otherwise, fire may result.
- When using a **400V-class inverter** to drive the motor, mount a suppresser filter or reactor on the inverter side, or provide reinforced insulation on the motor side; otherwise, dielectric breakdown may cause fire or damage to the equipment.
- **When driving an explosion-proof type motor with an inverter**, use one inverter for one motor. Use the approved inverter for the motor.
- When measuring the insulation resistance of an **explosion-proof type motor**, confirm that there is no gas, steam, or other explosive substance in the vicinity, in order to prevent possible explosion or ignition.

- Long cables cause voltage to drop. Select cables with appropriate diameter so that the voltage drop will be less than 2%.
- After wiring **outdoor and explosion-proof type motors**, check that terminal box mounting bolts are not loose, and correctly attach the terminal box cover.

6-1) Attaching and Detaching the Terminal Cover (**0.1~04kW 3-phase motor**)

(1) Detaching

As shown in Fig.8, hold both sides of the terminal box and pull it towards you. The cover will detach.

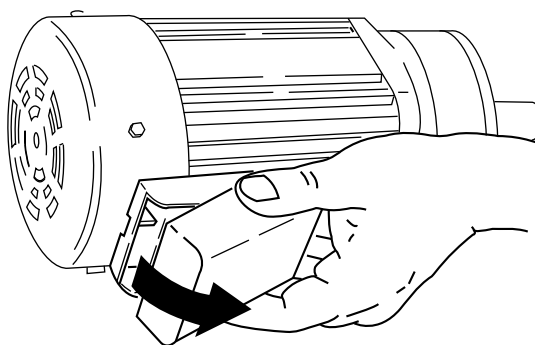

Fig. 8

(2) Attaching

Press the terminal box cover onto the terminal box case until it snaps into place.



6-2) Connection with Power Source Cable

Connecting method is shown below.

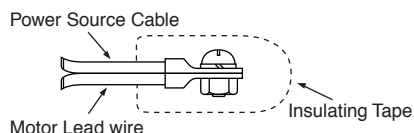

6-3) Measuring Insulation Resistance

- When measuring the insulation resistance, disconnect the motor from the control panel. Check the motor separately.

Measure the insulation resistance before wiring. The insulation resistance (R) varies according to the motor output, voltage, type of insulation, coil temperature, humidity, dirt, period of operation, test electrification time, etc. Usually, the insulation resistance exceeds the values shown in Table 10.

Table 10 Insulation Resistance

Motor voltage	Megohmmeter voltage	Insulation resistance (R)
Low-voltage motor of 600V or less	500V	1M (Ω) or more

Reference : The following equations are shown in JEC-2100.

$$R \geq \frac{\text{Rated Voltage (V)}}{\text{Rated Output (kW)} + 1000} \quad (\text{M}\Omega)$$

$$R \geq \frac{\text{Rated Voltage(V)} + \text{Speed(rpm)}/3}{\text{Rated Output(kW)} + 2000} \quad +0.5(\text{M}\Omega)$$

A drop in insulation resistance may be attributed to poor insulation. In that case, do not turn on the power. Contact our nearest agent, distributor, or sales office.

6-4) Protection Coordination

- (1) Use a molded case circuit breaker for protection against short circuit.
- (2) Use an overload protection device that protects the unit against a surge of electric current exceeding that shown on the rating plate.
- (3) For an **explosion-proof type motor**, use an overload protector that can protect the unit within the allowable binding hour by means of the locked rotor current shown on the rating plate.



6-5) Motor Connection

Fig.9 shows the motor connection and the standard specifications for terminal codes.

Fig. 9 Motor Connection and Terminal Code

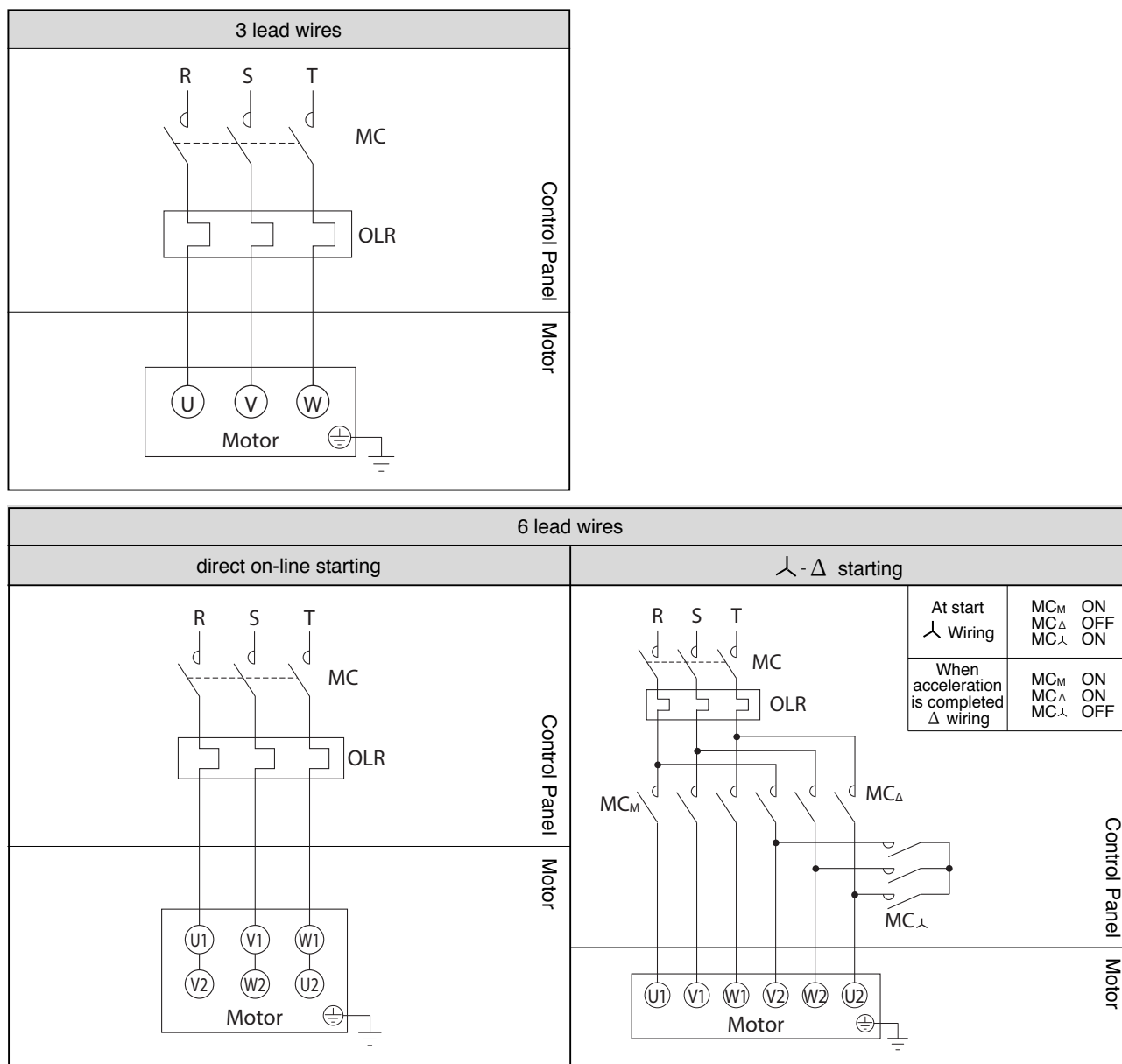

MC : Electromagnetic contactor
 OLR : Overload protection device

These should be furnished by the customer.

- This diagram shows cases for motors with standard Japanese domestic specifications. Please consult with us for motors with overseas specifications.
- Refer to the motor maintenance manual (Cat. No. MM1001E) for the handling of motor with a brake.

6-6) Trochoid Pump Connection

⚠ CAUTION

● Conduct priming shown in the maintenance manual, before the start up of the main motor, in case of forced oil lubrication by the trochoid pump; otherwise damage to the equipment may result.
 For forced oil lubrication by trochoid pump, prime the pump, as shown in the maintenance manual, before starting the main motor; otherwise, the equipment may be damaged.

- (1) Because forced lubrication by the trochoid pump is necessary for the models with trochoid pump system as in "8-2 Confirmation of Lubrication Method (page 17)", a separate power source should be prepared for the pump. (Refer to Table 6, 7 and Fig.10)
- (2) Refer to Fig.11 for the trochoid pump wiring. At this point, connect so that the pump motor will rotate the designated direction.
- (3) Establish an electrical interlocking device between the trochoid pump motor and main motor that satisfies the following two functions; (Refer to Fig.11)
 - ① Start-up time-The main motor stops when the trochoid pump stops.
 - ② During operation-The main motor stops when the trochoid pump stops for some unknown reason.
- (4) To assure optimal lubrication conditions, the trochoid pump should be started-up at least 30 seconds before the start-up of the main motor. (priming)

Table 6 Trochoid Pump Specification for **Beier portion**

Beier frame size		Horizontal type		Vertical type	
A type	B type	Trochoid pump	Pump motor	Trochoid pump	Pump motor
N10A	N8B	—	—	TOP-13AK	0.2kW 4P
15A	10B	—	—	TOP-208HBM-SU	0.4kW 4P
20A	15B	—	—	TOP-212HBM-SU	0.4kW 4P
30A	20B	—	—	TOP-216HBM-SU	0.75kW 4P
40A	30B	—	—	TOP-216HBM-SU	0.75kW 4P
50A	50B	TOP-212HB	0.75kW 4P	TOP-N330H	2.2kW 6P
75A	75B				
100A	75B				
150A	100B	TOP-N350HVB-7 With relief valve		TOP-N350HVB-7 With relief valve	2.2kW 6P
200A	150B				

Table 7 Trochoid Pump Specification for **Cyclo portion**

Cyclo frame size	Vertical type	
	Trochoid pump	Pump motor
6275	TOP-216HBVB-3 With relief valve	0.75kW 4P
6275DA	TOP-204HBVB-3 With relief valve	0.4kW 4P

Lubrication oil cooling device will be set separately for over 50A and 50B. Refer to "9. Lubricating Oil Cooling Device (page 28)."

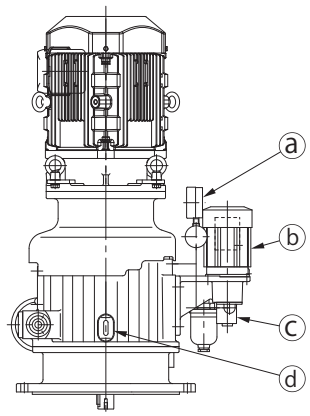

a	Pressure gauge
b	Motor (For Trochoid pump)
c	Trochoid pump
d	Oil level gauge

Fig. 10 Trochoid Pump Construction

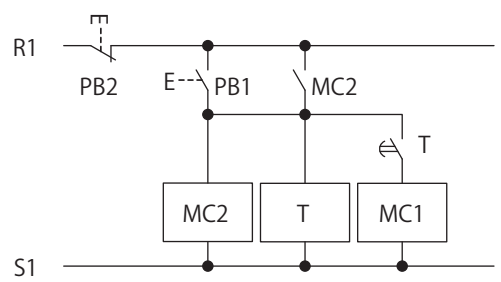
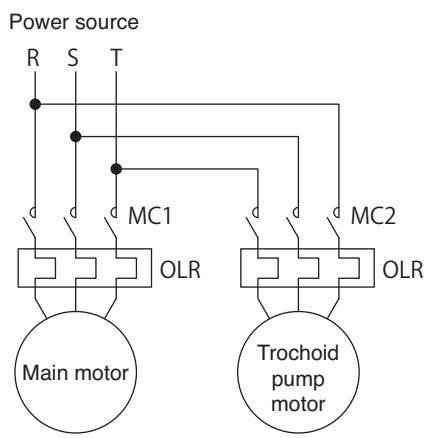

MC1 : Electromagnetic switch (For Main motor)
 MC2 : Electromagnetic switch (For Trochoid pump motor)
 PB1 : Push button switch (For Starting)
 PB2 : Push button switch (For Stopping)
 T : Timer (Approx. 30 sec. or more)

Fig. 11 Trochoid Pump Wiring Diagram

7. Operation

⚠ DANGER

- Do not approach or touch rotating parts (output shaft, etc.) during operation; loose clothing may become caught in these rotating parts and cause serious injury or death.
- When the power supply is interrupted, be sure to turn off the power switch. Unexpected resumption of power may cause electric shock, personal injury, or damage to the equipment.
- Do not operate the unit with the terminal box cover removed. Return the terminal box cover to the original position after maintenance, in order to prevent electric shock.
- Do not open the terminal box cover when power is supplied to an **explosion-proof type motor** ; otherwise, explosion, ignition, electric shock, personal injury, fire, or damage to the equipment may result.

⚠ CAUTION

- Do not put fingers or foreign objects into the opening of the variator; otherwise electric shock, personal injury, fire, or damage to the equipment may result.
- The variator becomes very hot during operation. Touching the unit may result in burns.
- Do not loosen the oil filler plug during operation; otherwise, hot, splashing lubricant may cause burns.
- If any abnormality occurs during operation, stop operation immediately; otherwise, electric shock, personal injury, or fire may result.
- Do not operate the unit in excess of the rating; otherwise, personal injury or damage to the equipment may result.

- **Oil-lubricated models** are shipped without oil. Units must be filled with the proper amount of recommended oil prior to start-up.
- Never turn speed control handwheel when Beier Variator is not in operation.
If handwheel is turned when the unit is not in operation, this will exert undue force on internal parts which in turn may break disc and other parts.
- When starting under full load condition, it is easier to start on low speed range.
This is because Beier Variator can give a larger torque in low speed range.
- Cushion start is required when the moment of inertia of driven machine is big. Please consult us.

After the unit is installed, filled with oil and properly wired, check the following before operating:

- (1) Is the wiring correct ?
- (2) Is the unit properly coupled with the driven machine ?
- (3) Are foundation bolts tightened firmly ?
- (4) Is the direction of rotation as required.
- (5) Does the oil level in **the oil-lubricated model** reach the top line of the oil gauge when the unit is at rest ?

After confirming these items without a load, gradually apply a load.

Check the items shown in Table 8.

Table 8 Items to Check During Initial Start-up and Break-in Period

Is abnormal sound or vibration generated ?	(1) Is the housing deformed because the installation surface is not flat ? (2) Is insufficient rigidity of the installation base generating excessive noise ? (3) Is the shaft center aligned with the driven machine ? (4) Is the vibration of the driven machine transmitted to the unit ?
Is the surface temperature of the variator abnormally high ?	(1) Is the voltage rise or drop substantial ? (2) Is the ambient temperature too high ? (3) Does the current exceed the rated current shown on the rating plate ?
Is the oil signal active? (When the lubrication is of the plungerpump type.)	If the balls in the oil signal are not moving up or down, there may be a lubrication problem.

If any abnormality is found, stop operation and contact our nearest agent, distributor, or sales office.

8. Daily Inspection and Maintenance

DANGER

- Do not handle the unit when cables are live. Be sure to turn off the power; otherwise, electric shock may result.
- Do not approach or touch any rotating parts (output shaft, etc.) during maintenance or inspection of the unit; loose clothing may become caught in these rotating parts and cause serious injury or death.
- Customers shall not disassemble or modify **explosion-proof type motors**; otherwise, explosion, ignition, electric shock, or damage to the equipment may result.
- The lead-in condition of an **explosion-proof type motor** shall conform to the facilities electrical codes, extension regulations, and explosion-proofing guide, as well as the maintenance manual ; otherwise, explosion, ignition, electric shock, or damage to the equipment may result.

CAUTION

- Do not put fingers or foreign objects into the opening of the products; otherwise, electric shock, injury, fire, or damage to the equipment may result.
- The products becomes very hot during operation. Touching the unit with bare hands; may result in serious burns.
- Do not touch the terminal when measuring insulation resistance; otherwise, electric shock may result.
- Do not operate the unit without a safety cover in place to shield rotating parts; otherwise loose clothing may become caught in the unit and cause serious injury.
- Promptly identify and correct, according to instructions in this maintenance manual, any abnormalities observed during operation. Do not operate until abnormality is corrected.
- Change lubricant according to the maintenance manual instructions. Be sure to use factory recommended lubricant.
- Do not change lubricant during operation or immediately after stopping operation; otherwise, burns may result.
- Supply/discharge grease to/from the motor bearing according to the maintenance manual instructions. Avoid contact with rotating parts; otherwise, injury may result.
- Do not operate damaged products; otherwise, injury, fire, or damage to the equipment may result.
- We cannot assume any responsibility for damage or injury resulting from an unauthorized modification by a customer.
- Dispose of the products lubricant as general industrial waste.
- When measuring the insulation resistance of an **explosion-proof type motor** , confirm that there is no gas, steam, or other explosive substance around the unit in order to prevent explosion or ignition.

- It is recommended to maintenance with disassembly the products after 20,000 hours or 3 to 5 years of operation to ensure a longer service life, although it depends on the operating conditions.
- Maintenance with disassembly should be done by appropriately skilld our factory technician. Please contact our nearest agent, distributor or sales office.

8-1) Daily Inspection

To ensure proper and continued optimum operation, use Table 9 to perform daily inspections.

Table 9 Daily Inspection

Inspection item		Details of inspection
Electric current		Is the current below the rated current shown on the rating plate ?
Noise		Is there abnormal sound ? Is there sudden change in sound ?
Vibration		Is there excessive vibration ? Does vibration change suddenly ?
Surface temperature		Is the surface temperature abnormally high ? Does the surface temperature rise suddenly ? (The temperature rise during operation differs according to the models. When the difference between the temperature of the casing surface and the ambient temperature is approx. 50°C, there will be no problem if there is no fluctuation.)
Oil level (Oil-lubricated model)	At rest	Does the oil level reach the top line of the oil gauge ?
	In operation	When compared to the oil level at rest, is this level different ?
	When using the trochoid pump	Is the function of oil signal or flow gauge normal ? When the function is abnormal, stop the unit and inspect it ; otherwise inadequate oil will cause poor lubrication of reduction portion, broken pump and fill-up the oil pipe.
Oil or grease leakage		Does oil or grease leak from the gear section ?
Foundation bolt		Are foundation bolts loose ?
Chain and V-belt		Are chain and V-belt loose ?

When any abnormality is found during the daily inspection, take corrective measures listed in section 10, Troubleshooting (page30.) If the abnormality cannot be corrected, contact our nearest agent, distributor or sales office.

8-2) Confirmation of Lubrication Method

• Refer to the applicable items regarding maintenance. Improper maintenance may decrease unit life.

- (1) Refer to Table 10–12 to confirm the gear lubrication method for your unit.
- (2) Table 14 lists maintenance manual pages that can be referenced regarding lubrication maintenance.

Table 10 Standard Lubrication System, BEIER part

A Type BEIER VARIATOR	BEIER size	N02A	N05A	N1A	N2A	N3A	N5A	N8A	N10A	15A	20A	30A	40A	50A	75A	100A	150A	200A
	Horizontal	Oil bath												Forced lubrication type				
	Vertical	Oil bath						Forced lubrication type						Forced lubrication type				
B Type BEIER VARIATOR	BEIER size	N02B	N05B	N1B	N2B	N3B	N5B	N8B	10B	15B	20B	30B	50B	75B	100B	150B		
	Horizontal	Oil bath												Forced lubrication type				
	Vertical	Oil bath						Forced lubrication type						Forced lubrication type				
D Type BEIER VARIATOR	BEIER size	N05D	N1D	N2D	N3D	N5D	N8D	N10D										
	Horizontal	Oil bath																
	Vertical	Oil bath																

Lubricating oil cooling device is attached.
 Refer to page 28.

Table 11 Standard Lubrication System, **A Type and B Type BEIER-CYCLO Variator, CYCLO Part**

Single reduction	Frame size	6075	6095	6105	6125	6135	6145	6165	6175	6185	6195	6205	6215	6225	6235	6245	6255	6265	6275		
	Horizontal	Grease				Oil bath															
	Vertical	Grease				Oil bath			Plunger pump (Self-lubrication)												Forced lubrication type
Double reduction	Frame size	6125DB	6130DB 6135DB	6130DC 6135DC	6160DA 6165DA	6160DC 6165DC	6170DC 6175DC	6180DB 6185DB	6190DA 6195DA	6205DA 6205DB	6215DA 6215DB	6225DA 6225DB	6235DA 6235DB	6245DA 6245DB	6255DA 6255DB	6265DA	6275DA				
	Horizontal	Grease	Grease				Oil bath														Forced lubrication type
	Vertical		Reduction ratio					-187	-210	-289	-522	-522									
			Reduction ratio	Grease				Plunger pump (Self-lubrication)													
				210-	231-	319-	595-	649-													
			Grease																		

Long-life grease series

Table 12 Standard Lubrication System, **D Type (ND Series) BEIER-CYCLO Variator, CYCLO Part** (at standard input speed by Table 13)

Single reduction	Frame size	6095	6105	6125	6135	6145	6165	6175	6185	6195										
	Horizontal	Grease				Oil bath														
	Vertical	Grease				Oil bath				Plunger pump (Self-lubrication)										
Double reduction	Frame size	6125DB	6130DC 6135DC	6160DB 6165DB	6170DB 6175DB	6180DA 6185DA	6180DB 6185DB	6190DA 6195DA	6190DB 6195DB	6205DA 6205DB	6215DA 6215DB	6225DA 6225DB	6235DA 6235DB	6245DA 6245DB	6255DA	6265DA	6275DA			
	Horizontal	Grease	Grease				Oil bath												Forced lubrication type	
	Vertical		Reduction ratio					104	-	-165	-319	-377					-559			
			Reduction ratio	Grease				Plunger pump (Self-lubrication)												
				121-	104-	195-	377-	473-					649-							
			Grease																	

Long-life grease series

1. For models with trochoid pump, before start of Beier Variator or Beier-Cyclo Variator, start pump motor and make sure there is no abnormality in lubrication. Then start main motor. For this requirement, interlock power supply for main motor with pump motor and give pump motor a lead time of 30 to 60 seconds. Wire pump motor so that it will run in the specified direction.
2. Oil filter (Fig. 12) is equipped on piping of forced lubrication type. Turn a handle on the oil filter and take out clogging. At the beginning of operation, clean the filter once a day.
3. Discharge the sludge from drain plug at the bottom edge when the machine stops.

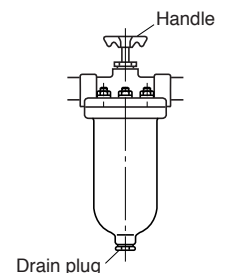

Fig. 12

Table 13 Standard input speed

A Type		BType		D Type (ND Series)	
Beier size	Standard input speed (r/min)	Beier size	Standard input speed (r/min)	Beier size	Standard input speed (r/min)
N02A-15A	1450/1750	N02B-10B	1450/1750	N05D-N10D	1450/1750
20A-40A	980/1165	15B-30B	980/1165		
50A-200A	720/870	50B-150B	720/870		

Table 14 Maintenance Manual Pages that can be Referenced Regarding Lubrication Maintenance

	Lubrication method		Pages where maintenance method is shown					
			Supply of oil/grease before initial operation after purchase	Oil/grease change period	Recommended oil/grease	Qty of oil/grease	Disposal of oil/grease	
Beier	Oil	Oil bath	Self-lubrication	Necessary	8-3) (1) P18	8-3) (2) P19	8-3) (3) P19	8-3) (4) (5) P20
		Trochoid pump lubrication						
Cyclo	Oil	Oil bath	Self-lubrication	Necessary	8-4) (1) P21	8-4) (2) P21	8-4) (3) P21	8-3) (4) (5) P21
		Plunger pump lubrication						
		Trochoid pump lubrication	Forced lubrication					
Grease	Grease	Long-life	Self-lubrication	Unnecessary	8-5) (1) P23	8-5) (1) P23	8-5) (3) P23	8-5) (4) P24
		Except for Long-life						
Variator Bearing	Grease	—	Self-lubrication	Unnecessary	8-6) (1) P25	8-6) (2) P25	8-6) (3) P25	8-6) (4) P25
Motor Bearing	Grease	—	Self-lubrication	Unnecessary	8-7) (1) P26	8-7) (2) P27	8-7) (1) P26	8-7) (3) P27

8-3) Oil Supply and Change for Beier

(1) Standard for lubricating oil change frequency

Table 15 **A Type and B Type BEIER Part**

Task	Conditions interval		Conditions of use
Supply of oil	At purchase		common
Oil change	First change	500 hrs operation or 6 months, whichever comes first.	common
	Second change and thereafter	5000 hrs operation or 1 year, whichever comes first.	Indoor temperature is 0-35C°
		2500 hrs operation or 6 months, whichever comes first.	Location where temperature cannot be kept at 0-35C°

In the case where the ambient temperature is high, there is intense change in temperature, or the air contains corrosive gas consult the oil producer. These situations may accelerate the deterioration of the oil.

Table 16 **D Type (ND Series) BEIER Part**

	Time for lubricating oil change	Remarks
Oil supply	At the time of purchase	—
Oil change	Every 20,000 hours or every 3 to 5 years	Increased frequency of supply for use under severe operating conditions

(2) Recommended Lubricants

Be sure to use a lubricant recommended by our company.

Table 17 Recommended Lubricating Oil **for A Type and B type**

Ambient Temperature	Shell	Mobil
-10°C – 5°C	Shell Tellus S2 M 46, 68	Mobil DTE 25, 26 (ISO VG46, 68)
0°C – 35°C	Shell Tellus S2 M 100 Shell Morlina S2 B 150	Mobil DTE Oil Heavy (ISO VG100) Mobil Vacuoline 528 (ISO VG150)
30°C – 50°C	Shell Morlina S2 B 220	Mobil Vacuoline 533,537 (ISO VG220, 320)

Table 18 Traction oil designated **for D Type (ND Series)**

Ambient temperature	Idemitsu	ENEOS
-10°C – 40°C	Daphne Alpha Drive P150	TD Oil 150

Always use correct lubrication oil for **D Type (ND Series) BEIER-CYCLO Variator**, which requires different lubrication oil for BEIER part and CYCLO part.

- ① For operation in winter or at a relatively low ambient temperature, use lubricating oils with lower viscosity. In the case of **forced lubrication models**, a plunger pump or trochoid pump may cause cavitation and necessary amount of oil may not be supplied. In such a case, a burned main body may result.
- ② For **N02A and M02B** with small input capacity in particular, use of lower viscosity oils is recommended.
- ③ Table 19 shows selection standard for viscosity of lubricating oil.

Table 19 Selection Standard for Oil Viscosity **for A Type and B Type**

Min allowable viscosity	Above 20mm ² /s at oil temp, during operation		Viscosity to obtain the oil film needed for transmission of the load
Max allowable viscosity	Oil bath lubrication models	less than 4300mm ² /s	Viscosity that allows Variators to start
	Forced oil lubrication models	less than 2200mm ² /s	Viscosity that allows plunger pumps and trochoid pumps to start

- ④ To ensure smooth start, use lubricating oil whose pour point is at least 5-10°C lower than ambient temperature.
- ⑤ If ambient temperature varies over a wide range, use lubricating oil whose viscosity remains stable, or lubricating oil that will satisfy requirements in Notes ③ and ④ in high viscosity index.
- ⑥ When units are always used at an ambient temperature other than 0 to 40°C, consult with the factory because depending on models it may need to change some parts or preheat or cool lubricating oil.

(3) Oil Quantity

Table 20, 21 shows approx. quantity of oil. Be sure to check the oil level through the oil gauge.

Table 20 Amount of Lubricating Oil (L) **for A Type and B Type BEIER Part**

BEIER size		N02A N05A N1A	N02B N05B	N2A N3A	N1B N2B	N5A N8A	N3B N5B	N10A N8B	15A 10B	20A 15B	30A 40A	20B 30B	50A 75A 100A	50B 75B	150A 100B	200A 150B
Horizontal	Basic model	0.7	1.8	3.7	4.3	11	10	20	56	85	95					
	With a gear reducer Built-in gear type	1.1	2.3	5.2	7.5	13	20	38	98	–	–					
Vertical	Basic model	1.5	4.1	7.6	6.5	12	13	23	56	85	95					
	With a gear reducer Built-in gear type	2.6	7.4	15	10	20	24	38	108	–	–					

Note: Regarding 50A–200A and 50B–150B, amounts in pipe and oil cooling device. Amounts of oil in the oil cooling device : 3.2L for 50A, 75A, 100A, 50B, and 75B, 6.7L for 150A and 100B, 13.5L for 200A and 150B.

Table 21 Amount of Lubricating Oil (L) **for D Type (ND Series) BEIER Part**

BEIER size	N05D N1D	N2D N3D	N5D N8D	N10D
Horizontal	1.2	2.4	4.8	8.7
Vertical	2.6	5.5	13.5	19.5

(4) Oil Supply

- Be sure to fill with oil when the unit is not operating.
- When the viscosity of oil is high, it may take some time for the oil to settle. Be careful not to over-fill. (If oil is filled above the upper line, the temperature will rise due to the churning heat of the oil.)
- Use the lower red line on the oil gauge, as a guideline for the normal oil level during operation. (Immediately following commencement of operation, the oil level may fall below the lower red line, but should not be of particular concern, since the oil level will recover, as the oil viscosity falls due to the drive operation.)

Oil supply for Horizontal Type (Refer to Fig.13)

- ① Remove the oil filler plug.
- ② Fill oil through oil filler port while checking oil level by the oil gauge.
- ③ Fill oil in place on the oil gauge.
- ④ Replace the oil filler plug.

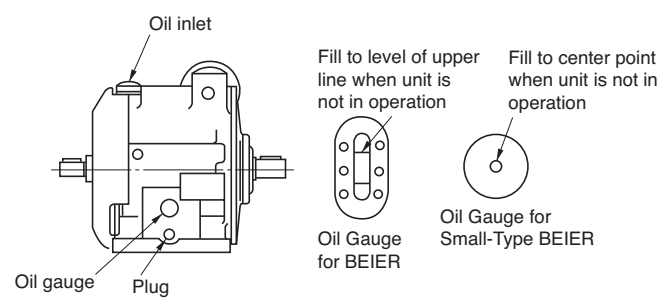

Fig.13

Oil supply for Vertical Type (Refer to Fig.14)

- ① Remove the oil filler plug.
- ② Fill oil through oil filler port while checking oil level by the oil gauge.
- ③ Fill oil in place on the oil gauge.
- ④ Replace the oil filler plug.

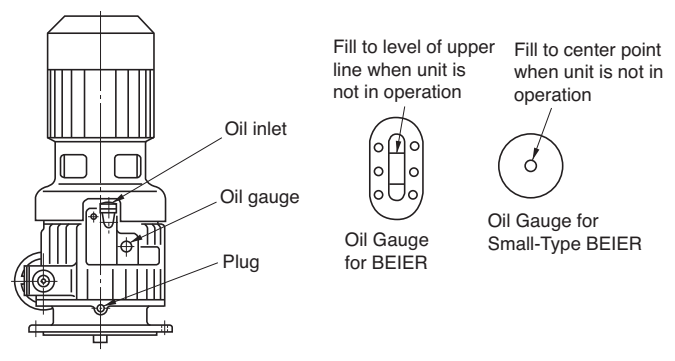

Fig.14

(5) Oil Discharge

Remove the drain plug shown in Fig.13, 14 to discharge oil

(6) Long-term Stoppage

Table 22 Long-Term Stoppage

Stoppage Period	Approx. 1 month	Change the oil and operate the unit for several minutes before stopping the unit.
	More than 1 month	Flush the unit, fill with rust-preventive oil, and operate the unit without a load for several minutes before stopping the unit.

• Before starting operation after long-term stoppage, always change the oil. This will ensure that the lubricant is free from deterioration that may have been caused by long-term stoppage.

8-4) Oil Supply and Change for Oil-lubricated CYCLO

(1) Oil Change Interval

Table 23 Interval

Task	Conditions interval		Conditions of use
Supply of oil	At purchase		common
Oil change	First change	500 hrs operation or 6 months, whichever comes first.	common
	Second change and thereafter	5000 hrs operation or 1 year, whichever comes first.	Indoor temperature is 0–35°C
		2500 hrs operation or 6 months, whichever comes first.	Location where temperature cannot be kept at 0–35°C

In the case where the ambient temperature is high, there is intense change in temperature, or the air contains corrosive gas consult the oil producer. These situations may accelerate the deterioration of the oil.

(2) Recommended Lubricants

Be sure to use a lubricant recommended by our company.

Recommended lubrication oil is the same for BEIER part and CYCLO part of **A Type and B Type BEIER-CYCLO Variator**.

Use designated traction oil in Table 18 for BEIER part and use recommended lubrication oil for Cyclo in Table 24 for **D Type (ND Series) BEIER-CYCLO Variator**.

Always use correct lubrication oil for both D Type (ND Series) BEIER part and CYCLO part because using mixed or incorrect oil can affect performance and life significantly.

Table 24 Recommended Lubricating Oil For A Type and B Type BEIER-CYCLO Variator

Ambient Temperature	Shell	Mobil
-10°C – 5°C	Shell Tellus S2 M 46, 68	Mobil DTE 25, 26 (ISO VG46, 68)
0°C – 35°C	Shell Tellus S2 M 100 Shell Morlina S2 B 150	Mobil DTE Oil Heavy (ISO VG100) Mobil Vacuoline 528 (ISO VG150)
30°C – 50°C	Shell Morlina S2 B 220	Mobil Vacuoline 533, 537 (ISO VG220, 320)

- ① For operation in winter or at a relatively low ambient temperature, use lubricating oils with lower viscosity.
- ② Table 25 shows selection standard for viscosity of lubricating oil.

Table 25 Selection Standard for the Oil Viscosity of CYCLO Part

Min allowable viscosity	Above 15mm/s at oil temp, during operation		Viscosity to obtain the oil film needed for transmission of the load
	Max allowable viscosity	Oil bath lubrication models	less than 4300mm ² /s
	Forced oil lubrication models	less than 2200mm ² /s	Viscosity that allows plunger pumps and trochoid pumps to start

- ③ To ensure smooth start, use lubricating oil whose pour point is at least 5°C lower than ambient temperature.
- ④ If ambient temperature varies over a wide range, use lubricating oil whose viscosity remains stable or lubricating oil that will satisfy requirements in Notes ② and ③ in high viscosity index.
- ⑤ When units are always used at an ambient temperature other than 0 to 40°C, consult with the factory because depending on models it may need to change some parts or preheat or cool lubricating oil.

(3) Oil Quantity

Table 26 shows approx. quantity of oil. Be sure to check the oil level through the oil gauge.

Table 26 Amount of Lubricating Oil (L)

Single reduction	Frame size	6075	6095	6105	6125	6135	6145	6165	6175	6185	6195	6215	6225	6235	6245	6255	6265	6275			
	Horizontal	Grease					0.7	0.7	1.4	1.9	2.5	4.0	8.5	10	15	16	21	29	56		
Vertical	Grease					1.1	1.1	1.0	1.9	2.0	2.7	7.5	10	12	15	42	40	60			
Double reduction	Frame size	6125DB	6130DB 6135DB	6130DC 6135DC	6160DA 6165DA	6160DB 6165DB	6170DB 6175DB	6180DA 6185DA	6160DC 6165DC	6170DC 6175DC	6180DB 6185DB	6190DA 6195DA	6190DB 6195DB	6205DA 6215DB	6225DA 6225DB	6235DA 6235DB	6245DA 6245DB	6255DA 6255DB	6265DA	6275DB	
	Horizontal	Grease							1.5	2.4	3.5	5.8	6.0	6.0	10	11	17	18	23	32	60
Vertical	Grease								1.0	1.9	2.0	2.7	2.7	11	14	18	23	29	42	51	60

(4) Oil Supply

- Be sure to fill with oil when the unit is not operating.
- When the viscosity of oil is high, it may take some time for the oil to settle. Be careful not to over-fill. (If oil is filled above the upper line, the temperature will rise due to the churning heat of the oil.)
- Use the lower red line on the oil gauge, as a guideline for the normal oil level during operation. (Immediately following commencement of operation, the oil level may fall below the lower red line, but should not be of particular concern, since the oil level will recover, as the oil viscosity falls due to the drive operation.)

Oil supply for Horizontal Type (Refer to Fig.15)

- The standard location of the oil gauge on a horizontal unit is on the right side (viewed from the slow speed shaft side). However, since the oil gauge may be placed on either side, select the side most convenient for observation.

- ① Remove the oil filler plug.
- ② Fill oil through oil filler port while checking oil level by the oil gauge.
- ③ Fill oil the upper line on the oil gauge.
- ④ Replace the oil filler plug.

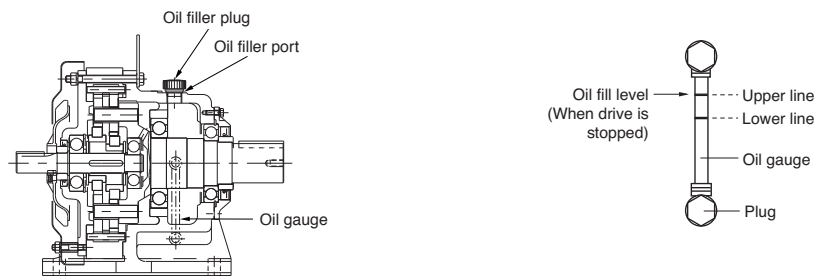

Fig. 15

Oil supply for Vertical Type (Refer to Fig.16)

- ① Remove the oil filler plug and, **except for sizes 6255 and 6265**, also remove the airvent.
- ② Fill oil through oil filler port while checking oil level by the oil gauge.
- ③ Fill oil the upper line on the oil gauge.
- ④ **Except for Sizes 6255 and 6265**, apply water proof sealing tape to threads of the air vent plug before re-installing.
- ⑤ Replace the oil filler plug.

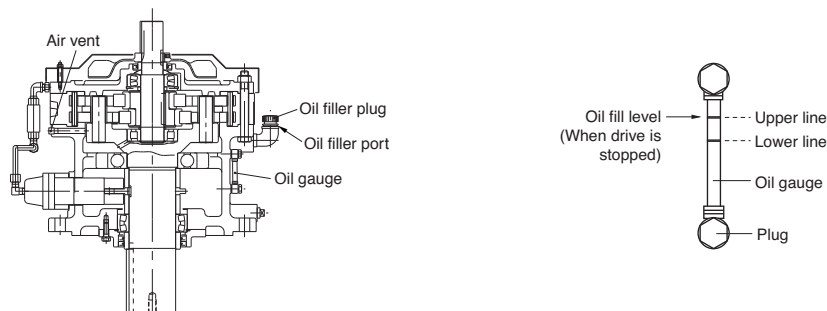

Fig. 16

(5) Oil Discharge

Remove the drain plug shown in Fig. 17 or the lower plug of oil gauge shown in Fig. 18 to discharge oil.

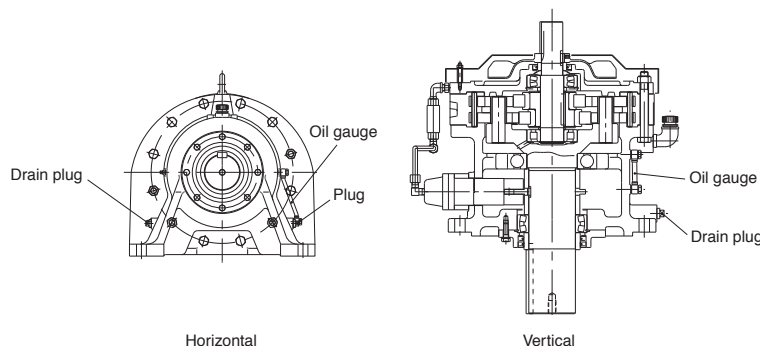

Fig. 17

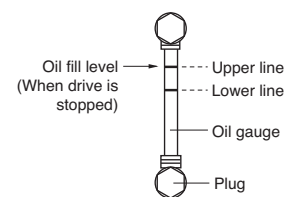

Fig. 18

(6) Long-term Stoppage

Table 27 Long-Term Stoppage

Stoppage Period	Approx. 1 month	Change the oil and operate the unit for several minutes before stopping the unit.
	More than 1 month	Flush the unit, fill with rust-preventive oil, and operate the unit without a load for several minutes before stopping the unit.

- Before starting operation after long-term stoppage, always change the oil. This will ensure that the lubricant is free from deterioration that may have been caused by long-term stoppage.

8-5) Grease Replenishment for **CYCLO Portion**

(1) Grease Replenishment Interval

Table 28 Grease Supply/Change Intervals

Model	Grease supply/change interval
Long-life grease series (<input type="checkbox"/> section in Table 11, 12 on page 17)	Long-life grease (BEN10-No.2) is supplied with these models, so operation can continue for extended periods. However, disassembly to change the grease after 20,000 hr or 3 to 5 years operation will ensure longer service life.
Grease-lubricated models other than maintenance-free	Refer to Table 29 for supply and change of grease.

Table 29 Grease Replenishment Interval
(Excl. Long-life grease series)

Hours of operation	Replenishment interval	Remarks
10 hr max./day	3-6 months	Reduce the supply interval when the operating conditions are severe or the frame size is large.
10-24 hr/day	500-1,000 hr	

(2) Recommended Grease

Table 30 Recommended Grease

Ambient temperature (°C)	Model	
	i) Long-life grease series (<input type="checkbox"/> section in Table 11,12 on page 17)	ii) Other grease model
	NIPPECO	COSMO
-10~50	BEN10-No.2	COSMO GREASE DYNAMAX SH No.2

- Do not use any grease other than those shown in Table 30.
- Models ii) in Table 30 are filled with COSMO GREASE DYNAMAX SH No.2 before shipment from our factory.
- The two kinds of grease for ii) in Table 30 may be mixed with each other.
- When the ambient temperature continuously exceeds the range of 0~40°C, modifications are needed.

(3) Grease Replenishment Quantity

These tables show grease replenishment quantities. Replenish using these tables as a guideline.

Table 31 Grease Replenishment Quantity (Guidelines)

Single Reduction

6075	6095	6105	6125
Long-life grease lubricated models. Replenishment is not required.			

Double Reduction

6125DB						
Long-life grease lubricated models. Replenishment is not required.						
613□DB	613□DC	616□DA	616□DB	616□DC		
20 – 30	40 – 60	20 – 30	40 – 60	85 – 125		
617□DB	617□DC	618□DA	618□DB	619□DA	619□DB	
40 – 60	85 – 125	40 – 60	150 – 225	110 – 165	150 – 225	
6205DA	6205DB	6215DA	6215DB	6225DA	6225DB	
110 – 165	150 – 225	150 – 225	250 – 375	150 – 225	335 – 500	
6235DA	6235DB	6245DA	6245DB	6255DA	6255DB	6265DA
250 – 375	370 – 550	250 – 375	370 – 550	335 – 500	500 – 750	500 – 750

- The symbol Å† in frame size can be "0" or "H".
- When changing grease, consult with us for filling quantity for each unit.

(4) Supply and Discharge of Grease

Procedure for supplying grease for **grease-lubricated models** (excl. Long-life grease series)

- ① Remove the grease discharge plug from the outside cover.
- ② Supply grease with a grease gun through the grease nipple in the inside cover section or motor connection cover.
- ③ Replace the grease discharge plug.

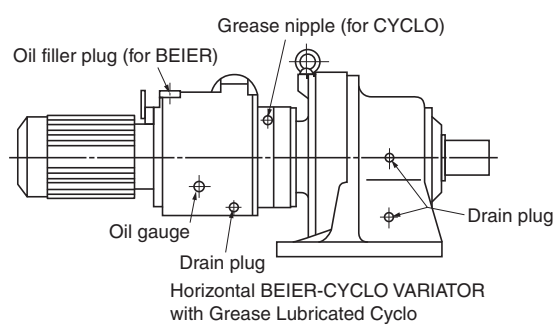

Fig. 19 Location of Grease Discharge Port

- Fill with grease during operation to ensure proper, uniform circulation.
- Fill with grease slowly.
- Grease supply exceeding the quantity shown in Table 32 will cause temperature rise from agitation heat or leakage of grease into BEIER part.

8-6) Maintenance of Variator Bearing

- Maintenance of bearing is needed for **BEIER vertical A Type and B Type**.
- Replenish grease from grease nipple (Fig 26 on page 32.)

(1) Interval

Table 32 Interval

Hours of operation	Replenishment interval	Remarks
10 hr max./day	3–6 months	Reduce the supply interval when the operating conditions are severe or the frame size is large.
10–24 hr/day	500–1,000 hr	

(2) Recommended Grease

Table 33 Recommended Grease

Ambient temperature	COSMO
-10–50	COSMO GREASE DYNAMAX SH No.2

- Do not use any grease other than those shown in Table 33.

(3) Grease Quantity

Table 34 Amount of Grease to Be Replenished on Open Bearing

BEIER frame size (Vertical type)		N10A N8B	15A 10B	20A 15B	30A 40A 20B 30B	50A 75A 100A 50B 75B	150A 200A 100B 150B
Basic type		5	20	35	25	35	100
With built-in gear type	Input shaft side	-	30	40	55	-	-
	Output shaft side	-	45	55	70	-	-
BEIEL-CYCLO Variator		5	20	35	25	35	100

- Replenish the amount of grease in the table above to the bearings.
- Replenish grease at least every three years even if you use the unit with the intermittent operation.
- After a long suspension, replenish grease right after starting the operation.

(4) Supply and Discharge of Grease (Refer to Fig.26 Construction on page 32)

Replenish the new grease from the grease nipple during the operation.

(Replenishing grease while BEIER is nonoperational may cause insufficient grease exchange.)

- Excessive grease may cause temperature rise of the bearing or leakage of the grease.
- Do not extend the replenishing interval by supplying more than the prescribed amount of grease.
- Omitting to replenish grease at the start or periodically may result in abnormal abrasion, noise, and breakage of the bearing.

8-7) Maintenance of Motor Bearing

- Standard motor uses a sealed bearing (not constructed for filling or draining grease).
- When using an other manufacturer's motor, refer to the operation manual for that motor.
Motor of 37kW or more are made by other manufacturers. Some specifications may be made by other manufacturers.
- Although it will depend on operation conditions, maintenance with disassembly after approximately 20,000 hours or 3 to 5 years will further increase lifetime.
- Contact the nearest authorized service station regarding maintenance with disassembly.

9. Lubricating Oil Cooling Device

Lubrication oil cooling device is standard attachment to **Beier frame size 50A – 200A, 50B – 150B**.

9-1) Installation

- Install the horizontal-type Beier Variator horizontally, install the vertical-type Beier Variator vertically, and install the lubricating oil cooling device horizontally.
- Install this device as close as possible to the main body of the Beier Variator. If it is installed too far apart, the oil pump will suffer faulty suction and excessive noise, temperature, and insufficient lubrication will result.
- If air is sucked only halfway out of the suction side piping of the oil pump, the amount of oil will be reduced as a result of this insufficient suction, thereby causing excessive noise in the oil pump. For this reason, airtightness must be maintained.

- (1) Install this device within 0.5m in a vertical upward location, or within 1.5m in a vertical downward location, and within 3m horizontally from main body of the Beier Variator. Minimize pipe bands.
- (2) The outline diagram shows both the Beier Variator and its lubricating oil cooling device. According to Fig. 20, install piping at the site along the broken lines. Use a gas pipe for the piping. Use a 1-1/2B to 2B gas pipe for the Beier Variator oil outlet, and use a 1B gas pipe for the oil inlet. Piping materials and pipe joints should be provided by the user since such piping will be installed at the site.

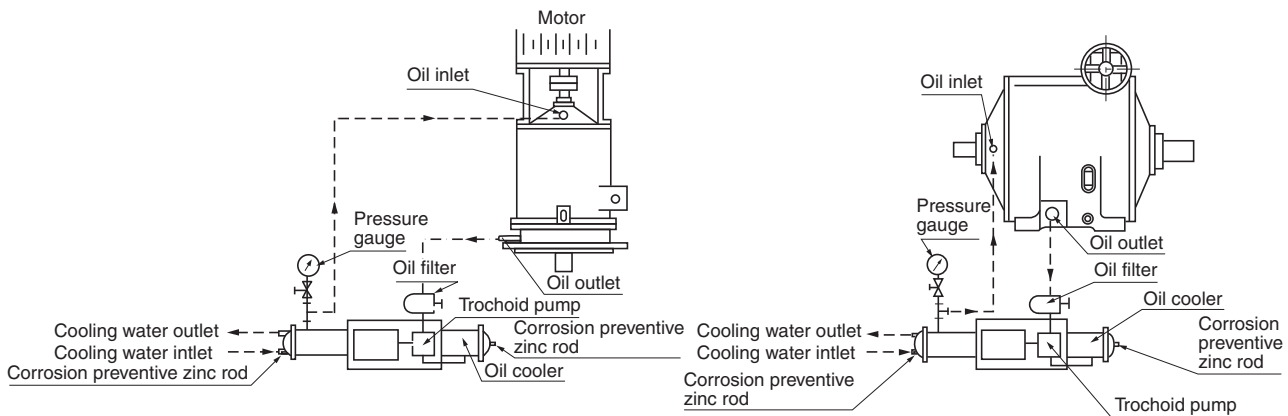

Fig. 20

9-2) Cooling Water

- For cooling water, use city water or industrial water.
- Table 35 gives a guideline for amount of cooling water supply. Adjust this amount depending on ambient temperature and operating conditions. It is desirable that Beier Variator be operated with its casing temperature kept within about 60°C.

9-3) Instructions on Starting

- Before starting the main body, be sure to start the oil pump of the lubricating oil cooling device and confirm lubrication. Allow 30 to 60 seconds lead time for the pump motor, and start the main motor only after the lubricating oil is circulating well. For the wiring, refer to the diagram on Fig. 11 page 14.

9-4) Daily Inspection and Maintenance of Oil Cooling Device

(1) Daily Inspection

Check the items below to evaluate whether cooling device is operating normally.

1. Is cooling water flowing normally?
2. Is oil circulating?
3. Is the temperature of BEIER case at 60°C or lower most of the time?

Table 35 Amount of Cooling Water Supply

Beier frame size		Amount of water supply (L/min)
50A, 75A, 100A 50B, 75B	Horizontal Model	6-8
	Vertical Model	10-15
150A 200A 100B 150B		15-20

(2) Maintenance

(a) Filter cleaning

- (i) Clogged filter cartridge may cause the abnormal noise by oil suction shortage of the oil pump. Continuing the operation under this state may result in supplying shortage of the oil to the variator as well as breakdown of the oil pump, and may consequently bring the variator itself to burning and other problems.
- (ii) Since the filter cartridge is a laminate, you can easily clean the clogged cartridge by turning the handle at the upper end of the filter. Be sure to turn the handle once or more.
- (iii) At the initial operation, since it is easy to clog the cartridge, turn the handle once or more a day for cleaning the cartridge.
- (iv) At a standstill, drain the accumulated dust in the lower part of the filter from the drain plug at the lower end.

(b) Inspection and cleaning of the oil cooler (cf. Fig.21)

- (i) Maintenance and cleaning the oil cooler of the lubricating oil cooling device periodically. The interval depends on the condition of the lubricating oil or the quality of the cooling water. Be sure to conduct the periodical inspection every 3 to 6 months.
- (ii) You can check the cooling water by removing a bonnet in the U-turn side of the cooling water. For checking the lubricating oil, drain the oil from the oil drain plug.
- (iii) At that time, be sure to check the corrosion preventive zinc rod for wear. Replace the rod if it has been worn to less than half of its original length. You may have to replace it 3 to 6 months depending on the quality of the cooling water. (There are zinc rods at three places.)
- (iv) In winter when you stop the operation at the place where the cooling water freezes, surely drain the water every day. Even at the ambient temperature that the cooling water freezes, if you can keep the casing temperature of the variator between 40 to 45 degree, reduce the amount of the cooling water or stop supplying the cooling water.

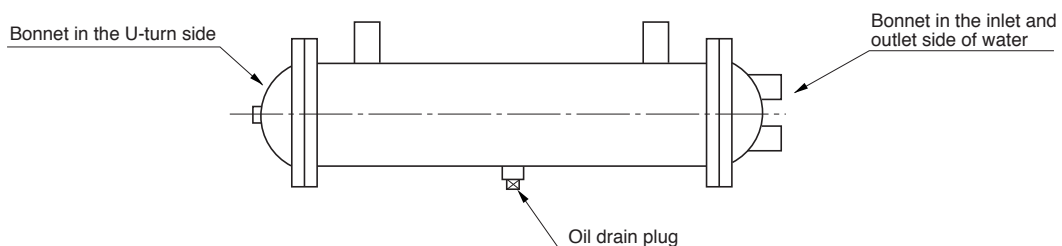

Fig. 21 Oil Cooler

10. Remote Control Equipment

10-1) Speed Control Device

(1) Checking Wiring and Speed Control Operation

- An example of control circuit for pilot motor and push button is shown in Fig. 22 . To check the connection, start the main motor first. Then, confirm that the revolution speed of output shaft increases while depressing the speed increase button (PB4). Also confirm that the revolution speed of output shaft decreases while depressing the speed decrease button (PB3). If the operation is reversed, interchange two phases of power supply to the pilot motor (PM).
- When highest speed or lowest speed has been reached, check to confirm slip clutch is idling, thereby positively protecting both PM and speed change control device.

- There is a possibility of speed control failure if clutch is left slipping for 30 seconds or more while speed control operation is sustained at maximum or minimum speed. Do not fail to stop PM as soon as possible by releasing pushbutton for control. To prevent such problem, check change in rotation speed using electromagnetic tachometer while conducting speed control operation.
- For cases when clutch stays slipping because of the content of speed control, optional limit switch system is recommended.
- When stopping Beier Variator, never turn speed control handwheel. For Beier with remote control, connect power source of speed control pilot motor from the secondary side of power source of main motor.

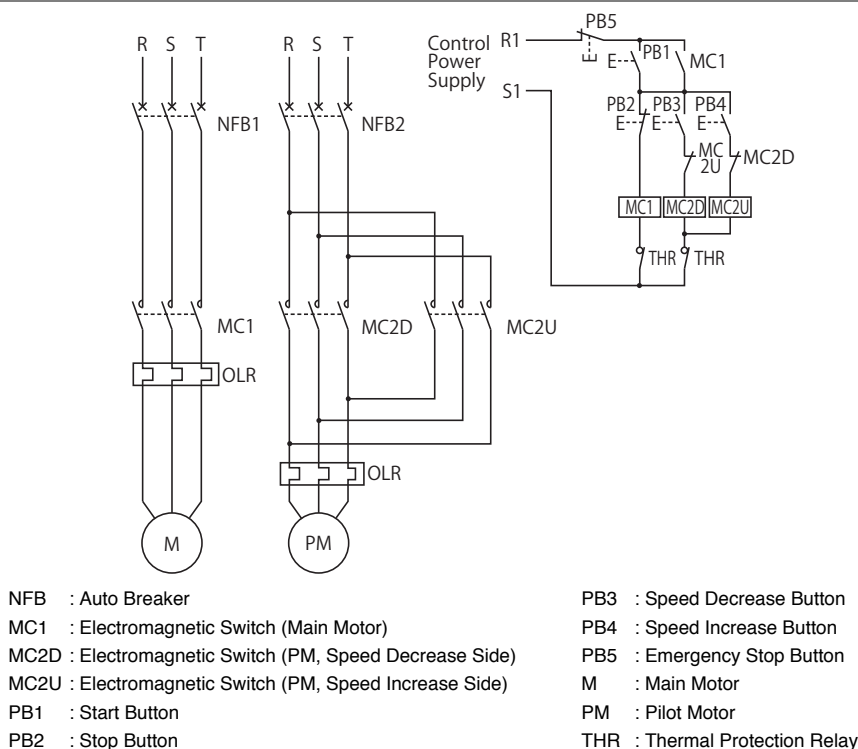

Fig. 22 Connection Diagram

(2) Handling of the Pilot Motor (PM)

Both worm gear-type and Cyclo Drive-type pilot motors are available to match the different Beier types.

Table 36 Beier Type and Pilot Motor Type

	Worm gear motor type	Cyclo Drive type
A Type	N02A, N05A, N1A, N2A, N3A, N5A, N8A, N10A	15A, 20A, 30A, 40A, 50A, 75A, 100A, 150A, 200A
B Type	N02B, N05B, N1B, N2B, N3B, N5B, N8B	10B, 15B, 20B, 30B, 50B, 75B, 100B, 150B
D Type	N05D, N1D, N2D, N3D, N5D, N8D, N10D	

· Handling of the worm gear-type pilot motor (PM)

This pilot motor is a maintenance-free motor, which incorporates a ball clutch as a safety device.

To remove the pilot motor from the Beier main body, pull out the PM mounting bolts (3 bolts) first.

Then pull out the whole PM from the operating shaft. If it becomes necessary to change the manual speed, shut off the power of the pilot motor, and use a hexagon bar wrench (nominal 5) to turn part A.

- Never conduct operations while the Beier Variator is stopped.

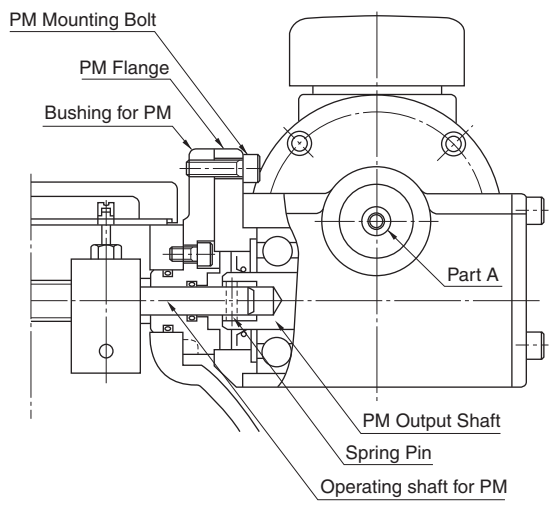

Fig. 23

· Setting torque of slip clutch for Cyclo Drive type

Torque of slip clutch has been set at the time of delivery by taking into consideration required moment of control shaft of Beier Variator, strength of inserted bush (mounting screws), etc. Therefore, no further adjustment is required except for special cases such as wear due to extended use. If need should arise to reestablish torque after delivery for some particular reason, proceed with the following steps referring to Fig. 24: Screw in adjusting nut ⑦ for full free length of spring ⑤ and set lock plug ⑥. Next, completely screw in adjusting bolt ⑩ into adjusting nut ⑦. With these steps, required turning force should be obtained. If any fine adjustment is needed, this can be accomplished by sliding position of adjusting nut ⑦ back and forth.

· Slip clutch is designed to be used in dry condition. Therefore, take extra care to keep clutch free from splashes of water, oil, etc.

· If manual speed change is required for variators with Cyclo drive type speed control device, follow the instruction below.

Loosen the grip ② and pull the handwheel ① toward to remove the jaw clutch ⑧ from the slip clutch ④, then manual speed change is available.

· Be careful for drop or loss of them, because if loosen the grip ② too much, the grip ② and the handwheel ① come off from the unit.

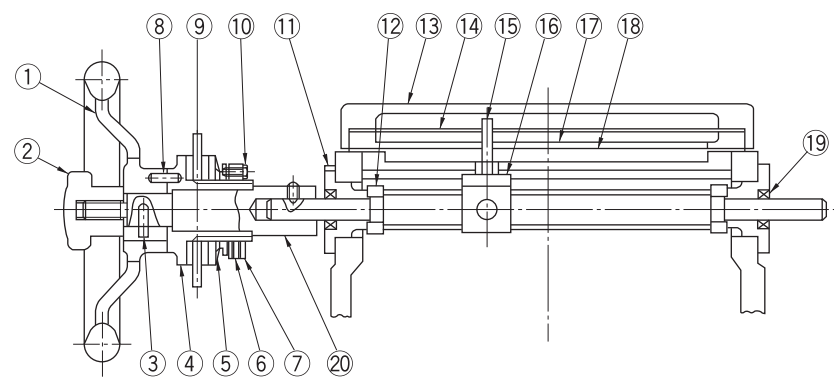

Part No.	Description	Q'ty	Part No.	Description	Q'ty	Part No.	Description	Q'ty	Part No.	Description	Q'ty
1	Handwheel	1	6	Lock plug	2	11	Bush	2	16	Shifting nut	1
2	Grip	1	7	Adjust nut	1	12	Spacer	2	17	Indicator Holder	1
3	Spring pin	1	8	Jaw clutch	2	13	Indicator plate	1	18	Gasket	2
4	Slip clutch	1	9	Chain wheel	1	14	Gasket	1	19	Oil seal	2
5	Spring	1-2	10	Adjust bolt	3	15	Pointer	1	20	Socket	1

Fig. 24

10-2) Operating instructions

(1) Starting

- Change speed only after starting Variator. Never attempt to perform speed change operation when the unit is at a standstill.

To prevent such erroneous operation, it is recommended that power to pilot motor (PM) be obtained from secondary side of main motor power supply. (Refer to Fig. 22 on page 28)

(2) Speed change

Pilot motor (PM) will run and speed change will take place while pushbutton switch for speed change control is being pressed. When desired revolutions have been reached, release pushbutton switch to stop PM. Then Variator will run at a constant speed thereafter. To reverse PM (for instance, in order to switch from acceleration to deceleration), depress pushbutton again for desired operation after PM has come to a stop.

(3) Stopping

- Stopping main motor during speed change operation can break discs or cause other trouble. Therefore, before opening switch for main motor, disconnect speed change operation circuit without fail.

In this case, erroneous operation can be prevented by making connection as shown in Fig.22 on Page 28.

11. Troubleshooting

If a problem occurs with the Beier variator, refer to Table 37 below and take the appropriate corrective action as soon as possible.

Table 37 Troubleshooting

Problem		Possible cause	Correction	
	The motor will not operate under load.	Power failure	Contact the electric power company.	
		Defective electric circuit	Check the circuit.	
		Blown fuse	Replace the fuse.	
		Protective device is engaged	Disengage protective device.	
		Load locking	Check the load and safety device.	
		Poor switch contact	Adjust the contact area.	
		Disconnection of motor stator coil	Return the unit to factory for servicing.	
		Bearing is broken	Return the unit to factory for servicing.	
		3-phase is functioning as single-phase.	Check the power supply with a voltmeter. Check the motor, coil in the transformer, contact, fuse, etc. and repair or replace them.	
The motor runs without a load but the output shaft does not rotate.		Damage due to overloading of gears	Return the unit to factory for servicing.	
The output shaft turns without a load	When a load is applied	The switch is heated.	Insufficient capacity of switch	Replace with specified switch.
		Fuse tripping	Overload	Decrease the load to the specified value.
			Insufficient capacity of fuse	Replace with specified fuse.
		The speed will not increase and the motor is overheating.	Overload	Decrease the load to the specified value.
			Voltage drop	Contact the electric power company.
		The motor stops.	Overload	Decrease the load to the specified value.
	Short-circuited motor stator coil		Return the unit to factory for servicing.	
	The key is missing		Install a key.	
	The motor runs in the reverse direction.	The bearing is burned.	Return the unit to factory for servicing.	
		Poor adjustment of protective device	Adjust the protective device.	
		Connection error	Change the connection.	
	Fuse tripping	The outlet wire is short-circuited.	Return the unit to factory for servicing.	
Poor contact between motor and starter		Complete the connection.		
Excessive temperature rise		Overload	Decrease the load to the specified value.	
		Voltage drop or rise	Contact the electric power company.	
		The ambient temperature is high.	Improve the ventilation method.	
		Damaged bearing	Return the unit to factory for servicing.	
		Abnormal wear of gear or disc due to overloading	Return the unit to factory for servicing.	
Oil leakage	Leakage of oil/grease from input/output shaft section	Damaged oil seal	Return the unit to factory for servicing.	
	Leakage of oil/grease from the contact surfaces of case or cover	Loose bolts	Tighten bolts correctly.	
	Leakage of oil/grease into motor	Damaged oil seal	Return the unit to factory for servicing.	
		Excessive oil/grease supply	Remove excess oil/grease.	
Abnormal sound Abnormal vibration		Entry of dust and foreign matter into bearings or damaged bearings.	Return the unit to factory for servicing.	
		Damaged gear or disc.	Return the unit to factory for servicing.	
		Distortion of housing because the installation surface is not flat	Make the installation base flat or make adjustment using shims.	
		Resonance due to insufficient rigidity of installation base	Reinforce the installation base to increase rigidity.	
		Nonalignment of shaft with driven machine	Align the shaft centers.	
		Transmission of vibration from the driven machine	Individually operate the variator to check the source of the sound.	
Abnormal sound from motor		Entry of foreign matter	Return the unit to factory for servicing.	
		Damaged bearings	Return the unit to factory for servicing.	

12. Construction Drawings

12-1) Basic A and B Type BEIER VARIATOR (Horizontal)

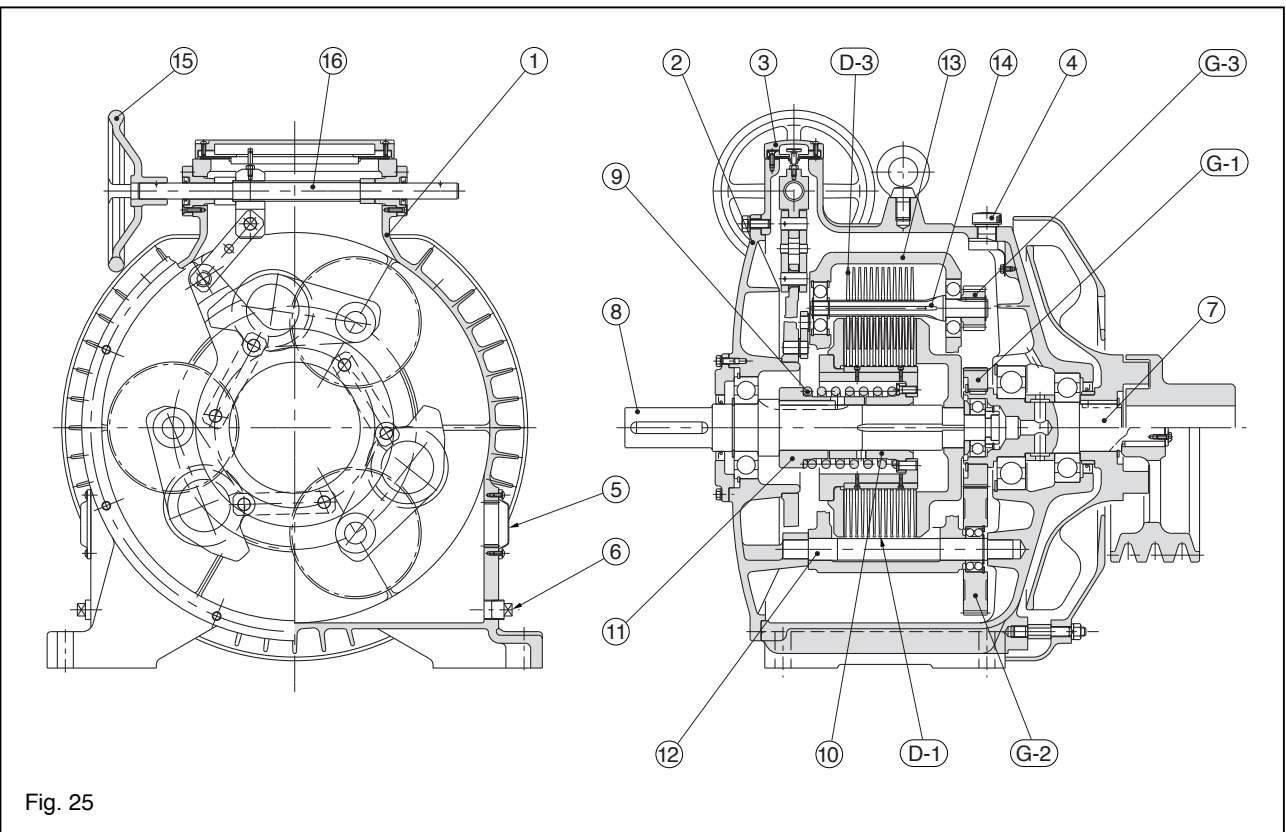

12-2) Basic A and B Type BEIER VARIATOR (Vertical)

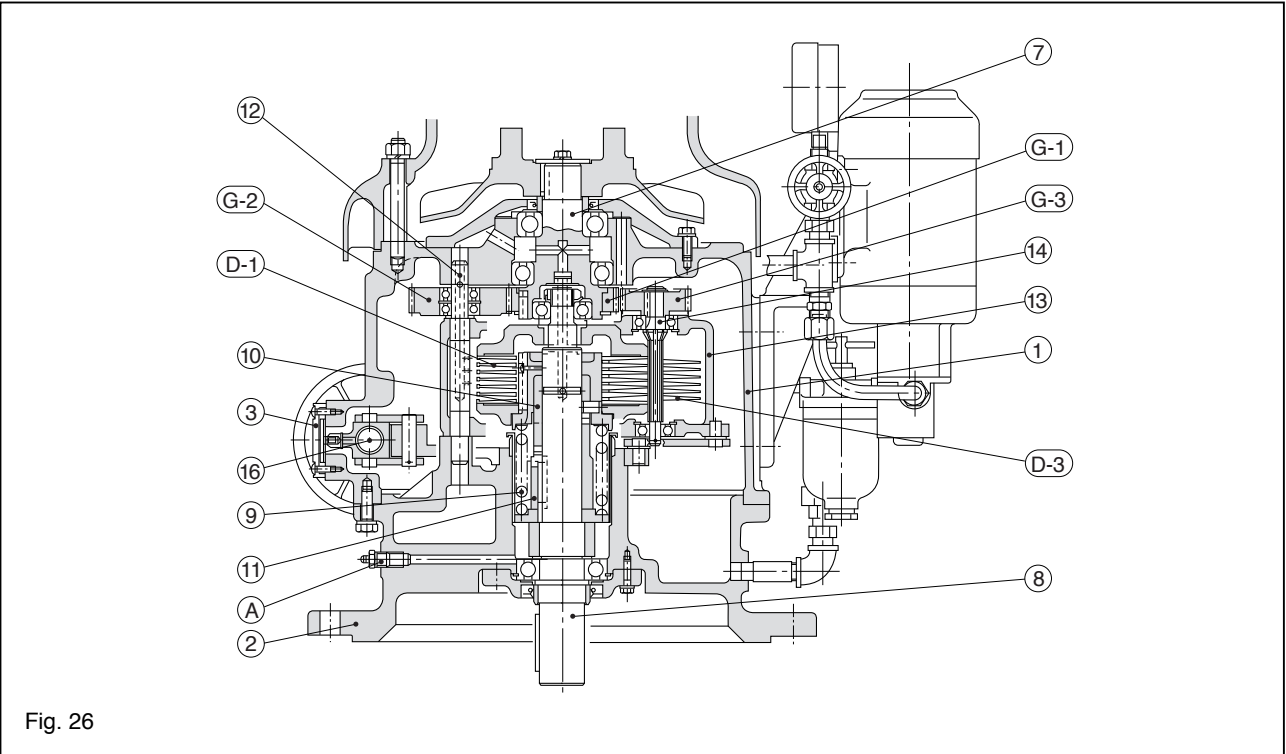

Ⓐ Frame sizes equipped with grease nipple are shown on page 25.

12-3) BEIER-CYCLO VARIATOR

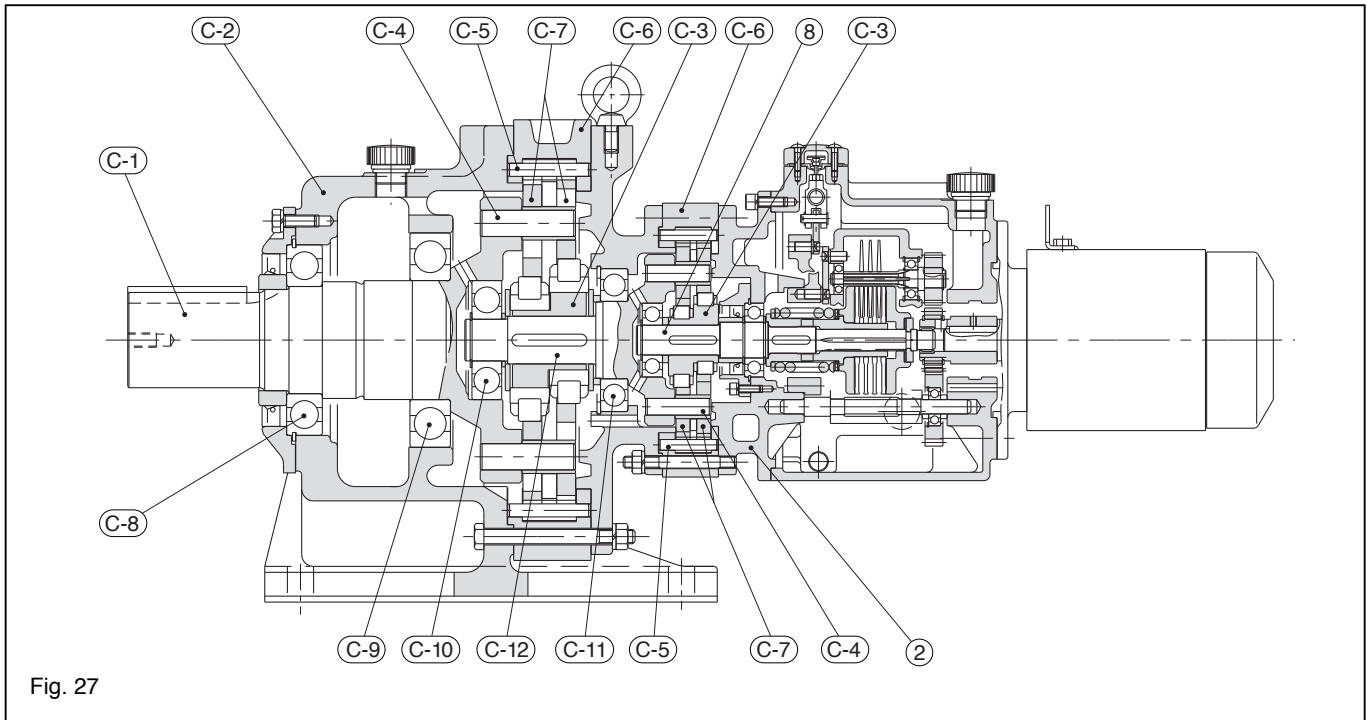

Fig. 27

Main Parts

Part No.	Description	Part No.	Description	Part No.	Description	Part No.	Description
1	Casing	10	Face cam I	D-1	Flange disc	C-5	Ring gear housing pin
2	Cover (Flange cover in Fig. 27)	11	Face cam II	D-3	Cone disc	C-6	Ring gear housing
3	Indicator plate	12	Swing shaft	G-1	Input shaft gear	C-7	Cycloid disc
4	Oil filler plag	13	Bracket (arm)	G-2	Idler gear	C-8	Slow speed shaft bearing A
5	Oil gauge	14	Spline shaft	G-3	Spline shaft gear	C-9	Slow speed shaft bearing B
6	Drain plug	15	Hand wheel	C-1	Slow speed shaft	C-10	Intermediate shaft bearing A
7	Input shaft	16	Shifting screw	C-2	Horizontal casing	C-11	Intermediate shaft bearing B
8	Output shaft (high speed shaft in Fig. 27)			C-3	Eccentric	C-12	Intermediate shaft
9	Spring			C-4	Slow speed shaft pin		

12-4) D Type BEIER VARIATOR (Horizontal)

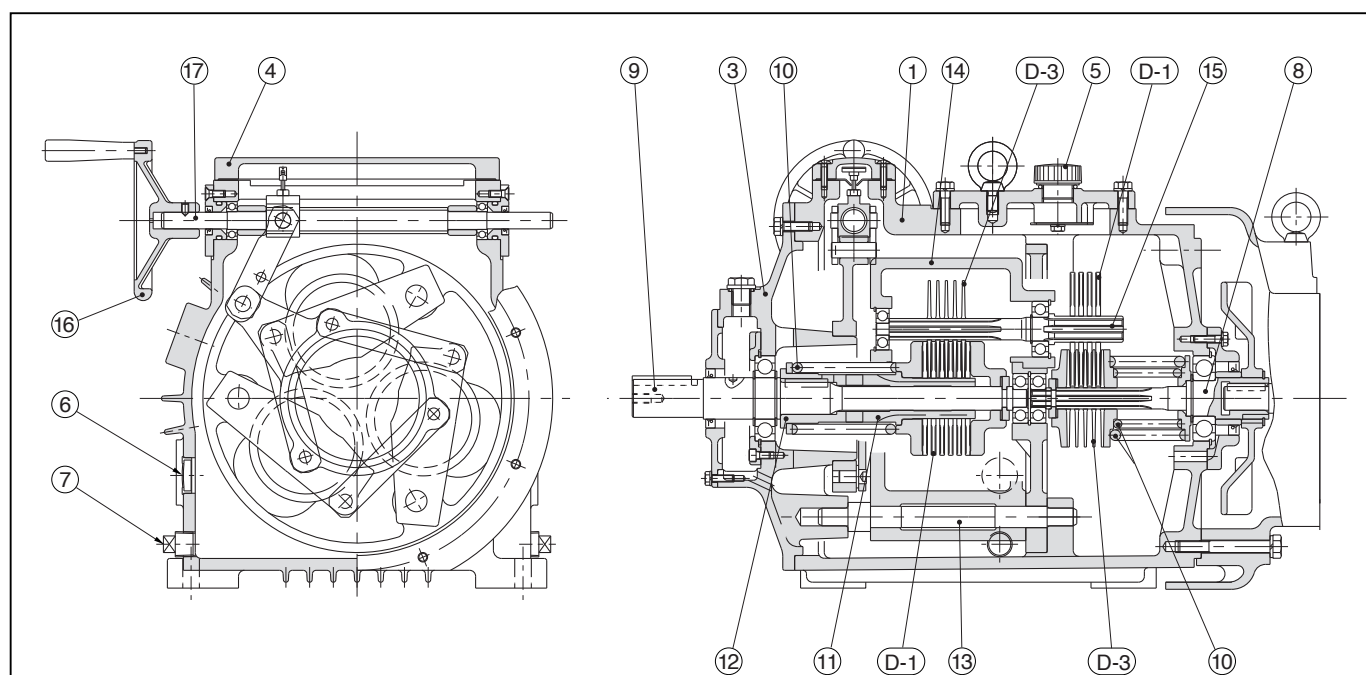

Fig. 28

Main Parts

Part No.	Description	Part No.	Description	Part No.	Description	Part No.	Description
1	Casing	6	Oil gauge	11	Face cam I	16	Hand wheel
2	Base	7	Drain plug	12	Face cam II	17	Shifting screw
3	Cover	8	Input shaft	13	Swing shaft	D-1	Flange disc
4	Indicator plate	9	Output shaft	14	Bracket (arm)	D-3	Cone disc
5	Oil filler plug	10	Spring	15	Spline shaft		

12-5) D Type BEIER VARIATOR (Vertical)

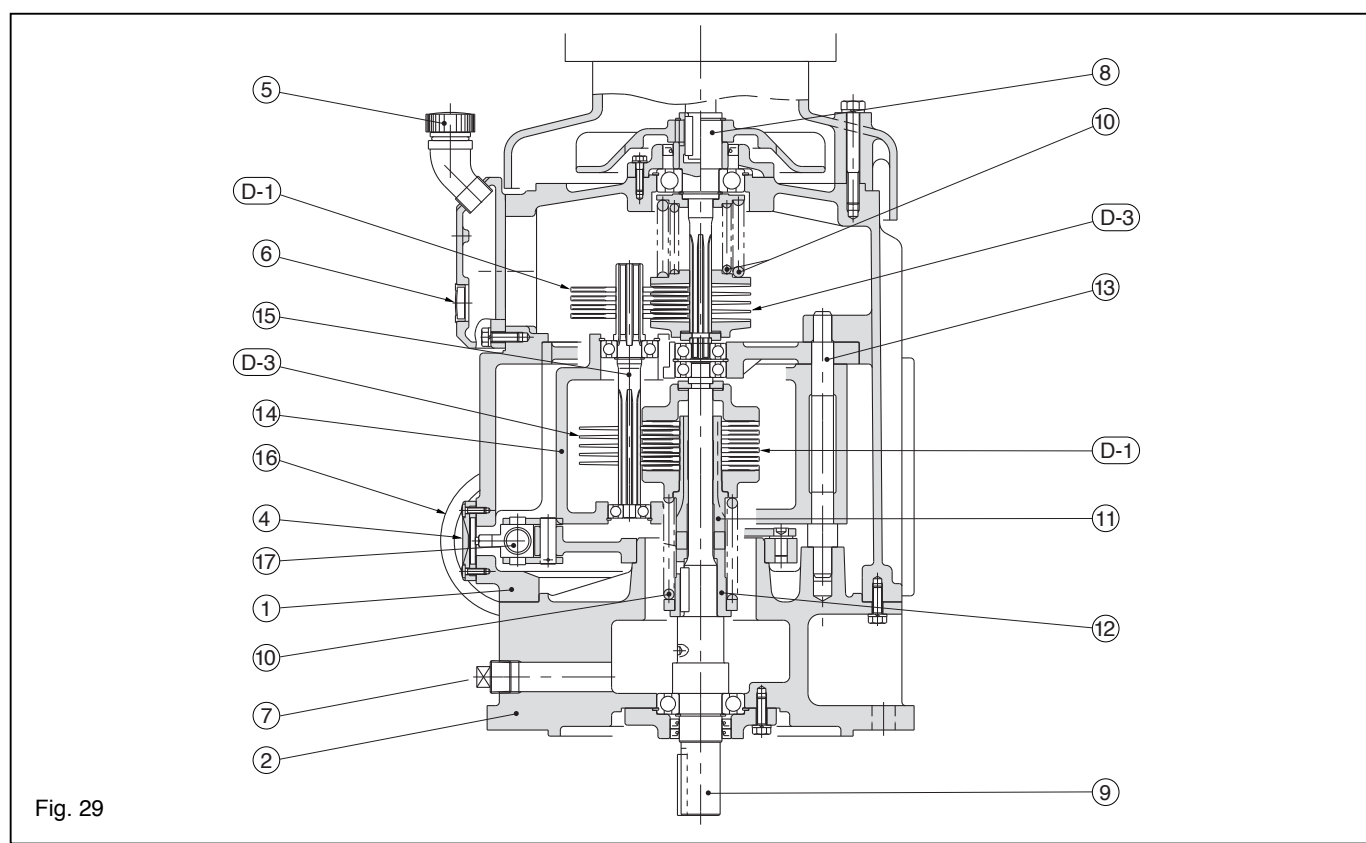

Fig. 29



12-6) Motor

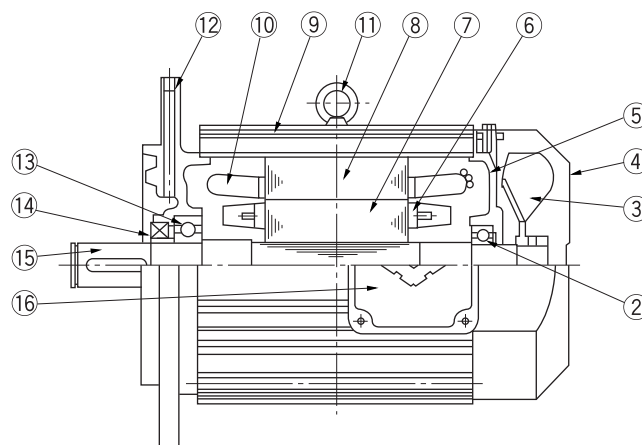

Fig 30 Example of Construction of 80–112M Frame

Main Parts

No.	Part Name	No.	Part Name	No.	Part Name
1	Bearing cover	7	Rotor core	13	Motor shaft bearing A
2	Motor shaft bearing B	8	Stationary core	14	Oil seal
3	Fan	9	Stator frame	15	Motor shaft
4	Fan cover	10	Stator windings	16	Conduit box
5	End bracket	11	Eyebolt		
6	Rotor conductor short circuit ring	12	Flange bracket		

13. Warranty

The scope of our warranty for our products is limited to the range of our manufacture.

Warranty Period	The warranty period for the Products shall be 18 months after the commencement of delivery or 18 months after the shipment of the Products from the seller's works or 12 months from the Products coming into operation, whichever comes first.
Warranty Condition	<p>In the event that any problem or damage to the Product arises during the "Warranty Period" from defects in the Product whenever the Product is properly installed and combined with the Buyer's equipment or machines, maintained as specified in the maintenance manual, and properly operated under the conditions described in the catalog or as otherwise agree upon in writing between the Seller and the Buyer or its customers; the Seller will provide, at its sole discretion, appropriate repair or replacement of the Product, without charge, at a designated facility, except as stipulated in the "Warranty Exclusions" described below.</p> <p>However, if the Product is installed or integrated into the Buyer's equipment or machines, the Seller shall not reimburse the cost of: removal or re-installation of the Product or other incidental costs related thereto, any lost opportunity, any profit loss or other incidental or consequential losses or damages incurred by the Buyer or its customers.</p>
Warranty Exclusions	<p>Notwithstanding the above warranty, the warranty as set forth herein shall not apply to any problem or damage to the Product that is caused by :</p> <ol style="list-style-type: none"> 1. installation, connection, combination or integration of the Product in or to the other equipment or machine that is rendered by any person or entity other than the Seller ; 2. insufficient maintenance or improper operation by the Buyer or its customers, such that the Product is not maintained in accordance with the maintenance manual provided or designated by the Seller ; 3. improper use or operation of the Product by the Buyer or its customers that is not informed to the Seller, including, without limitation, the Buyer's or its customers' operation of the Product not in conformity with the specifications, or use of lubricating oil in the Product that is not recommended by the Seller ; 4. any problem or damage to any equipment or machine to which the Product is installed, connected or combined, or on any specifications particular to the Buyer or its customers ; 5. any changes, modifications, improvements or alterations to the Product or those functions that are rendered on the Product by any person or entity other than the Seller ; 6. any parts in the Product that are supplied or designated by the Buyer or its customers ; 7. earthquake, fire, flood, sea-breeze, gas, thunder, acts of God or any other reasons beyond the control of the Seller ; 8. normal wear and tear, or deterioration of the Product's parts, such as bearings, oil-seals ; 9. any other troubles, problems or damage to the Product that are not attributable to the Seller.

Worldwide Locations

U.S.A

Sumitomo Machinery Corporation of America (SMA)
1453 Cornwall Blvd. Chesapeake, VA 23323, U.S.A.
TEL (1)757-485-3355 FAX (1)757-485-7490

Canada

SM Cyclo of Canada, Ltd. (SMC)
1453 Cornwall Road, Oakville, Canada ON L6J 7T5
TEL (1)905-469-1050 FAX (1)905-469-1055

Mexico

SM Cyclo de Mexico, S.A. de C.V. (SMME)
Av. Desarrollo 541, Col. Finsa, Guadalupe,
Nuevo León, México, CP67132
TEL (52)81-8144-5130 FAX (52)81-8144-5130

Brazil

Sumitomo Industrias Pesadas do Brasil Ltda. (SHIB)
Rodovia do Acucar (SP-075) Km 26
Itu, Sao Paulo, Brasil
TEL (55)11-4886-1000 FAX (55)11-4886-1000

Chile

SM-Cyclo de Chile Ltda. (SMCH)
Camino Lo Echevers 550, Bodegas 5 y 6,
Quilicura, Región Metropolitana, Chile
TEL (56)2-892-7000 FAX (56)2-892-7001

Argentina

SM-Cyclo de Argentina S.A. (SMAR)
Ing Delpini 2230, B1615KGB Grand Bourg,
Malvinas Argentinas, Buenos Aires, Argentina
TEL (54)3327-45-4095 FAX (54)3327-45-4099

Guatemala

SM Cyclo de Guatemala Ensambladora, Ltda. (SMGT)
Parque Industrial Unisur, 0 Calle B 19-50 Zona 3,
Bodega D-1 Delta Bárcenas en Villa Nueva, Guatemala
TEL (502)6648-0500 FAX (502)6631-9171

Colombia

SM Cyclo Colombia, S.A.S. (SMCO)
Parque Industrial Celta, Km 7.0 Autopista Medellín,
Costado Occidental, Funza, Cundinamarca, Colombia
TEL (57)1-826-9766

Peru

SM Cyclo de Perú, S.A.C (SMPE)
Jr. Monte Rosa 255, Oficina 702, Lima,
Santiago de Surco, Perú
TEL (51)1-713-0342 FAX (51)1-715-0223

Germany

Sumitomo (SHI) Cyclo Drive Germany GmbH (SCG)
Cyclostraße 92, 85229 Markt Indersdorf, Germany
TEL (49)8136-66-0 FAX (49)8136-5771

Austria

Sumitomo (SHI) Cyclo Drive Germany GmbH (SCG)
SCG Branch Austria Office
Gruentalerstraße 30A, 4020 Linz, Austria
TEL (43)732-330958 FAX (43)732-331978

Belgium

Hansen Industrial Transmissions NV (HIT)
Leonardo da Vincilaan 1, Edegem, Belgium
TEL (32)34-50-12-11 FAX (32)34-50-12-20

France

SM-Cyclo France SAS (SMFR)
8 Avenue Christian Doppler, 77700 Serris, France
TEL (33)164171717 FAX (33)164171718

Italy

SM-Cyclo Italy Srl (SMIT)
Via dell' Artigianato 23, 20010 Cornaredo (MI), Italy
TEL (39)293-481101 FAX (39)293-481103

Spain

SM-Cyclo Iberia, S.L.U. (SMIB)
C/Gran Via Nº 63 Bis, Planta 1, Departamento 1B
48011 Bilbao–Vizcaya, Spain
TEL (34)9448-05389 FAX (34)9448-01550

United Kingdom

SM-Cyclo UK Ltd. (SMUK)
Unit 29, Bergen Way, Sutton Fields Industrial Estate,
Kingston upon Hull, HU7 0YQ, East Yorkshire,
United Kingdom
TEL (44)1482-790340 FAX (44)1482-790321

Turkey

SM Cyclo Turkey Güç Aktarım Sis. Tic. Ltd. Sti. (SMTR)
Barbaros Mh. Çiğdem Sk. Ağaoğlu, Office Mrk. No:1 Kat:4 D.18
Ataşehir, Istanbul, Turkey
TEL (90)216-250-6069 FAX (90)216-250-5556

India

Sumi-Cyclo Drive India Private Limited (SDI)
Gat No. 186, Raison Industrial Park, Alandi Markal Road,
Fulgaon-Pune, Maharashtra, India
TEL (91)96-0774-5353

China

Sumitomo (SHI) Cyclo Drive China, Ltd. (SCT)
11F, SMEG Plaza, No. 1386 Hongqiao Road,
Changning District, Shanghai, China (P.C. 200336)
TEL (86)21-3462-7877 FAX (86)21-3462-7922

Hong Kong

SM-Cyclo of Hong Kong Co., Ltd. (SMHK)
Rm 1301, CEO Tower, 77 Wing Hong Street,
Cheung Sha Wan, Kowloon, Hong Kong
TEL (852)2460-1881 FAX (852)2460-1882

Korea

Sumitomo (SHI) Cyclo Drive Korea, Ltd. (SCK)
Royal Bldg. 19 Rm. 913, 5 Saemunan-ro 5-Gil Jongro-Gu
Seoul, Korea 03173
TEL (82)2-730-0151 FAX (82)2-730-0156

Taiwan

Tatung SM-Cyclo Co., Ltd. (TSC)
22 Chungshan N. Road 3rd., Sec. Taipei, Taiwan 104,
R.O.C.
TEL (886)2-2595-7275 FAX (886)2-2595-5594

Singapore

Sumitomo (SHI) Cyclo Drive Asia Pacific Pte. Ltd. (SCA)
15 Kwong Min Road, Singapore 628718
TEL (65)6591-7800 FAX (65)6863-4238

Philippines

Sumitomo (SHI) Cyclo Drive Asia Pacific Pte. Ltd. Philippines Branch Office (SMPH)
C4 & C5 Buildings Granville Industrial Complex, Carmona,
Cavite 4116, Philippines
TEL (63)2-584-4921 FAX (63)2-584-4922

Vietnam

SM-Cyclo (Vietnam) Co., Ltd. (SMVN)
Factory 2B, Lot K1-2-5, Road No. 2-3-5A,
Le Minh Xuan Industrial Park, Binh Chanh Dist.,
HCMC, Vietnam
TEL (84)8-3766-3709 FAX (84)8-3766-3710

Malaysia

SM-Cyclo (Malaysia) Sdn. Bhd. (SMMA)
No.7C, Jalan Anggerik Mokara 31/56, Kota Kemuning,
Seksyen 31, 40460 Shah Alam, Selangor Darul Ehsan,
Malaysia
TEL (60)3-5121-0455 FAX (60)3-5121-0578

Indonesia

PT. SM-Cyclo Indonesia (SMID)
Jalan Sungkai Blok F 25 No. 09 K, Delta Silicon III,
Lippo Cikarang, Bekasi 17530, Indonesia
TEL (62)21-2961-2100 FAX (62)21-2961-2211

Thailand

SM-Cyclo (Thailand) Co., Ltd. (SMTH)
195 Empire Tower, Unit 2103-4, 21st Floor, South
Sathorn Road, Yannawa, Sathorn, Bangkok 10120,
Thailand
TEL (66)2670-0998 FAX (66)2670-0999

Australia

Sumitomo (SHI) Hansen Australia Pty. Ltd. (SHAU)
181 Power St, Glendenning, NSW 2761, Australia
TEL (61)2-9208-3000 FAX (61)2-9208-3050

Japan

Sumitomo Heavy Industries, Ltd. (SHI)
ThinkPark Tower, 1-1 Osaki 2-chome, Shinagawa-ku,
Tokyo 141-6025, Japan
TEL (81)3-6737-2511 FAX (81)3-6866-5160

Specifications, dimensions, and other items are subject to change without prior notice.



Power Transmission & Controls Group

Headquarter ThinkPark Tower, 1-1 Osaki 2-chome, Shinagawa-ku, Tokyo 141-6025, Japan

No.BM2001E-3.3

EA10 Printed 2020.07