

## ASTERO® Motor with Electromagnetic Brake Maintenance Manual

- The gear head and motor should be handled, installed and maintained by trained technicians. Carefully read this manual and all accompanying documents before use.
- A copy of this manual should be sent to the actual user of the gear unit.
- This manual should be maintained by the user.

### 1. Safety and other precautions

**⚠ CAUTION**

**General**

- The gear head and motor should be operated only within its name plate and catalogue ; otherwise, electric shock, injury or damage to a system may occur.
- Keep hands and all foreign objects from the internal moving part of the gear unit and motor; otherwise, electric shock, injury, fire or damage to a system may occur.
- Damaged units should be taken off-line; otherwise, injury or fire may occur.
- Do not remove the nameplate.
- Any modifications or alterations of any kind, to the unit, will void the warranty and all subsequent claims.

**Transport**

- Exercise ample care not to drop the unit and fall during transport.

**Installation**

- Do not place any inflammables around the gear head and motor; otherwise, fire may result.
- Do not place any objects that will hinder ventilation around motor; otherwise, cooling effect is reduced, and may lead to a possible fire hazard and a burn due to excessive heat built-up.
- Do not touch the key way at the shaft end or on the inside of the gear unit and motor; otherwise, injury may result.
- When the unit is used in food processing applications vulnerable to oil contamination, install an oil pan or other such device to cope with rare oil leaking. Otherwise, oil leakage may damage products.

**Coupling with other machines**

- Install appropriate guard devices around rotation parts ; otherwise, injury may result.
- Confirm the direction of rotation before coupling the unit with its driven machine. Difference in the direction of rotation may cause injury or damage to the system.

**Wiring**

- Do not touch lead wire when measuring the insulation resistance. Electric shock may result.

**Daily inspection and maintenance**

- Clean this product regularly. Instead of using water, detergent, or solvents for cleaning, use a brush and wipe it with a dry cloth. Also, ensure that there are no obstacles or things that may be affected in the surrounding area during cleaning.

**⚠ DANGER**

**Wiring**

- Connect a power cable to the motor according to the connection diagram or maintenance manual; otherwise, electric shock or fire may result.(Without terminal box, exercise insulation in the connecting part.)
- Do not forcibly curve, pull or clamp the power cable and lead wires; otherwise, electric shock may result.
- Correctly ground the grounding bolt; otherwise, electric shock may result.
- Use power source stated in the nameplate; otherwise, motor's burning or fire may result.

**Operation**

- Never approach or touch any rotating parts (shaft, etc.) during operation; otherwise, loose clothing caught in these rotation parts may result in severe injury.
- When the power supply is interrupted, be sure to turn off the power switch. Unexpected resumption of power may cause injury or damage to the equipment.

**Daily inspection and maintenance**

- Never approach or touch any rotating parts (shaft, etc.) during maintenance ; otherwise, loose clothing caught in these rotating parts may result in severe injury.

**Inspection upon delivery**

- Verify that the unit received is in fact the one ordered. When a different product is installed, injury or damage to the system may result.

### 2. Wiring diagram

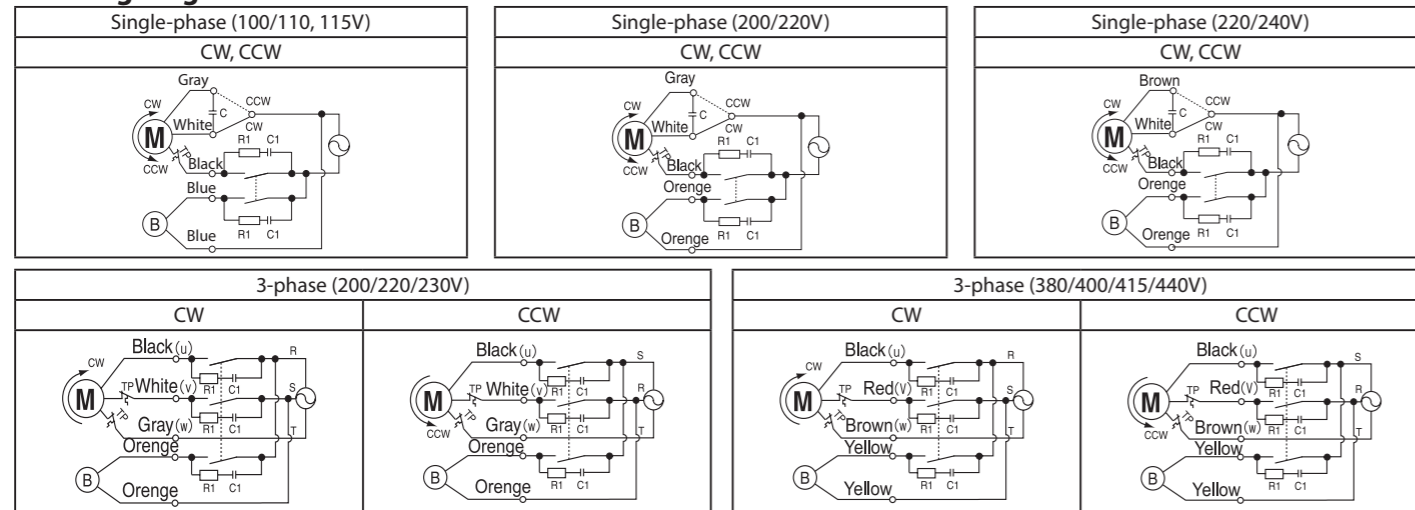

- Rotating direction viewed from the shaft end of motor.
- The brake is nonexcitation operation type.
- 6w motor has no TP (Thermal protector).

- CR circuit is for the surge voltage protection.
- R1=10-200Ω (1/4W or larger)
- C1=0.1-0.33 μF (for AC125V or AC250V)

CW : Clockwise  
 CCW : Counter Clockwise  
 C : Capacitor  
 TP : Thermal protector

### 3. Inspection upon deliver

- Confirm the contents of nameplates for motor type and condenser.
- Gearhead and motor which have same frame size (number) and same heat treatment symbols can be combined.

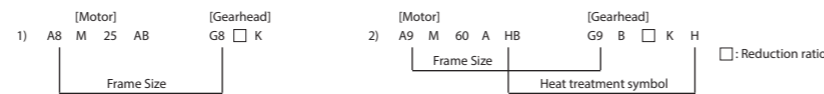

Fig.1 Combination example of motor and gearhead

Table 1. Combination table of motor type and condenser

Condenser	DMF-25305	DMF-25235	DMF-45804	DMF-45704	DMF-25605	DMF-25455	DMF-45155	DMF-45125	DMF-251006	DMF-25705	DMF-45255	DMF-45205
Motor type	A6R06AB	A6R06BB	A6R06CB	A6R06DB	A7R15AB	A7R15BB	A7R15CB	A7R15DB	A8R25AB	A8R25BB	A8R25CB	A8R25DB
Condenser	DMF-251506	DMF-251206	DMF-45355	DMF-45305	DMF-252506	DMF-252006	DMF-45655	DMF-45505	DAL-25306	DMF-25256	DMF-45755	DMF-45605
Motor type	A9R40AB	A9R40BB	A9R40CB	A9R40DB	A9R60AHB	A9R60BHB	A9R60CHB	A9R60DHB	A9R90AHB	A9R90BHB	A9R90CHB	A9R90DHB

### 4. Overheat protection device

- Thermal protector type
  - When motor is run with overload or is stopped and overheated, in order to protector motor coil, overheat protection device, TP (Thermal protector), is built in the coil.
  - This TP has an automatic reset system.
  - So, if temperature in the coil returns to the normal level, this motor runs automatically.
- Impedance protector type
  - Impedance protector motor is designed to enlarge impedance of coil winding, reduce the input current at motor restriction, and not to exceed the allowable max.temperature.
  - "ZP" as impedance protector is displayed in the nameplate.

### 5. Rating

- Motor is designed to be suited to the usage conditions, and its usage limitation to fit to the usage conditions is called rating.
- There are some ratings, like continuous, short-time, and repetition rating. SHI's induction motor is continuous rating and reversible motor is short-time rating (30min.).

### 6. How to install motor and gearhead

- Install motor and gearhead, putting both contact surfaces together like fig.2 while rotating them little by little. Forcing into motor shaft and bumping into the inside of gearhead, at assembly, may cause abnormal noise by broken gear and shorten the operating life.
- When holding down transfer systems, such as chain, pulley, and sprocket, to the gearhead shaft with keyway, process keyway in the system side as well and hold them down by attached key.
- When holding transfer fittings down to gearhead shaft, giving impacts may cause damages or shortening operation life of gearhead. Please do not hit the gearhead shaft.

Motor capacity	Gearhead size	Screw size	Tightening torque
6W	G6	M4	2N·m
15, 25W	G7, G8	M5	2.5N·m
40, 60, 90W	G9	M6	3N·m

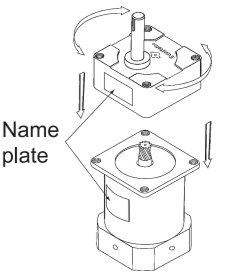

Fig. 2

### 7. Standard specifications

Motor type	Electromagnetic brake motor	
	Single-phase motor	3-phase motor
Item	6W-90W 4P	25W-90W 4P
Capacity range	6W-90W 4P	25W-90W 4P
Protection method enclosure	6-40W : IP23 Totally enclosed non ventilated type 60W, 90W : IP23 Totally enclosed fan cooled type	25-40W : IP23 Totally enclosed non ventilated type 60W, 90W : IP23 Totally enclosed fan cooled type
Power source	100V 50/60Hz, 110V 60Hz 115V 60Hz 200V 50/60Hz, 220V 60Hz 220 ~ 240V 50Hz	200V 50/60Hz, 220V 50/60Hz 380V 50/60Hz, 400V 50/60Hz 415V 50/60Hz, 440V 50/60Hz
Insulation Class	Motor:130(B)/Break:B	Motor:130(B)/Break:B
Time rating	30 minutes rating	Continuous rating
Starting method	Capacitor start	Direct start
Lead wires	5 wires UL Style 3266 20AWG	5 wires UL Style 3271 20AWG
Standards	CE marking (Low voltage direction), UL standard, CCC standard (Safety standard depends on the motor specification)	
Insulation resistance	At least 100MΩ when measured with a 500V DC meager between the motor coil and case at normal temperature and humidity after motor has reached rated torque.	
Insulation withstand voltage	Normal function when a 1500V, 50/60Hz current is applied between the motor coil and case for 1 minute at normal temperature and humidity after the motor has reached rated torque.	
Temperature rise	The temperature rise value (ΔT) should be no more than 60°C (no more than 45°C for motors with fans) when measured by the prescribed method after the motor has reached rated torque.	
Overheating protector (TP)	Built in thermal protector (auto restore type) Release:120±5°C Release:77±5°C	
Gear	Lubrication method Grease lubrication. Grease is loaded at shipment.	
Paint	Color Astero silver	
Ambient conditions	Location	Indoors (Minimal dust and humidity) When you install the equipment under the above condition, it is regarded as the special specification. Make inquiries to us. Install the equipment where it is easy to carry out inspection and maintenance. Install the equipment on a mount having sufficient rigidity.
	Temperature	-10-40°C
	Humidity	Under 85%RH with no condensation
	Elevation	Under 1,000m
	Atmosphere	Well ventilated location, free of corrosive gases, explosive gases, vapors and dust.

### 8. Warranty

The scope of warranty of our delivered products is limited only to what we manufactured.

Warranty (period and description)

Warranty period	The warranty period applies only to new products and represents 18 months after the shipment or 12 months after the actual operation, whichever is shorter.
Description	If the product failed within the warranty period, during which despite a proper mounting, connection and maintenance & administration are followed according to the maintenance manual, and the product is properly run based on the specification on the catalog or under conditions agreed separately, we will repair or provide an alternative product at our discretion for free of charge, except the exclusions below. However, as far as the product is connected with customers' other devices, we will not indemnify those expenses on dismantling from/mounting on the devices, etc. and other associated construction expenses, transportation expenses and opportunity loss and operation loss the customers suffered from, and other indirect damages.
Exclusion from the warranty	The following items will be excluded from the warranty: 1. A breakdown resulting from defects in the installation of the product and coupling with other devices, etc. 2. A breakdown resulting from insufficient maintenance & administration and improper handling of the product, including a case that the product is not stored according to our defined storage manual. 3. A breakdown resulting from operation which does not fall within our specification and other operation conditions and use status we hardly can know. 4. A breakdown resulting from defects, special specification, etc. of device prepared and connected by customer. 5. A breakdown resulting from disassembly, parts replacement, and modification conducted by the customer. 6. A breakdown resulting from defects in parts supplied or specified by customers. 7. A breakdown caused by inevitable force including earthquake, fire, flood disaster, salt damage, gas damage, and lightning strike, etc. 8. Natural wear and tear, abrasion, and deterioration of such relevant consumable parts as a bearing and oil seal, etc. under normal usage. 9. A breakdown caused for reasons not attributable to each of the above item.

Specifications, dimensions, and other items are subject to change without prior notice.