

FINE CYCLO[®] High Precision Gearboxes

A Series
D Series
DA Series
C Series
T Series
UA Series

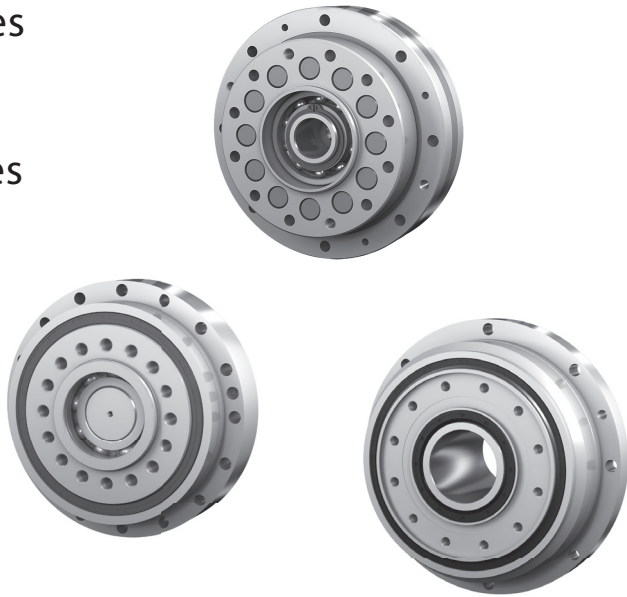

<Note>

- This product should be handled by only those who have been trained for the work.
Please read this manual carefully before use.
- Deliver this manual to the customer who will actually use the product.
- This instruction manual should be carefully stored.



[Introduction] Safety Precautions

- Carefully read this maintenance manual and all accompanying documents before use (installation, operation, maintenance, inspection, etc.). Thoroughly understand the machine, information about safety, and all precautions for correct operation.
Maintain this manual for future reference.
- Pay particular attention to the "DANGER" and "CAUTION" warnings regarding safety and proper use.



Improper handling may result in physical damage, serious personal injury and/or death.



Improper handling may result in physical damage and/or personal injury.

Matters described in  may lead to serious danger depending on the situation.

Be sure to observe important matters described herein.

DANGER

- Transport, installation, plumbing, wiring, operation, maintenance and inspections should be handled by properly trained technicians; otherwise, electric shock, injury, fire, or damage to the equipment may result.
- When the unit is to be used in a system for transport of human beings, a protective device should be installed. There is a risk of personal injury or damage to the equipment due to runaway or falling.
- When the unit is to be used in an elevator, install a protective device on the elevator side to prevent it from falling; otherwise, personal injury, death, or damage to the equipment may result.

CAUTION

- When the unit is used in food processing applications, machines for cleanroom and so on, vulnerable to oil contamination, install an oil pan or other such device to cope with grease leakage due to breakdown or failure; otherwise, grease leakage may cause failure of the unit, etc.

【Contents】

Contents

【Introduction】 Safety Precautions	1
【Contents】	2
【1】 Inspection Upon Delivery	3
【2】 Storage	5
【3】 Transportation	6
【4】 Installation	7
【5】 Lubrication	8
【6】 Coupling with Other Machines	15
【7】 Operation	32
【8】 Daily Inspection and Maintenance	33
【9】 Structural Drawing	35
【10】 Warranty	41

[1] Inspection Upon Delivery

⚠ CAUTION

- Unpack the unit after verifying that it is positioned right side up; otherwise, injury may result.
- Verify that the unit received is in fact the unit ordered. When a different unit is installed, injury or damage to the equipment may result.
- Do not remove the nameplate.

Upon delivery and receipt of the reducer check the following. If a nonconformity or problem is found,

contact our nearest agent, distributor, or sales office.

[1] Do the items on the nameplate conform to what was ordered?

[2] Were there any parts that were broken during transport?

[3] Are all bolts and nuts tightened firmly?

1-1 How to Refer to the Nameplate



When making an inquiry, advise us of the [1] Nomenclature and [2] Serial No.

1-2 Lubrication Method

- All models of the CYCLO Drive for Precision Control use grease lubrication.
- There are models that have been greased at the time of shipment, and models that have not been greased. For models that have not been greased, lubricate with the recommended grease before operation. For details, refer to P8-14.

[1] Inspection Upon Delivery

1-3 Nomenclature

The meanings of the symbols are as follows. Verify that the nomenclature matches that of the order.

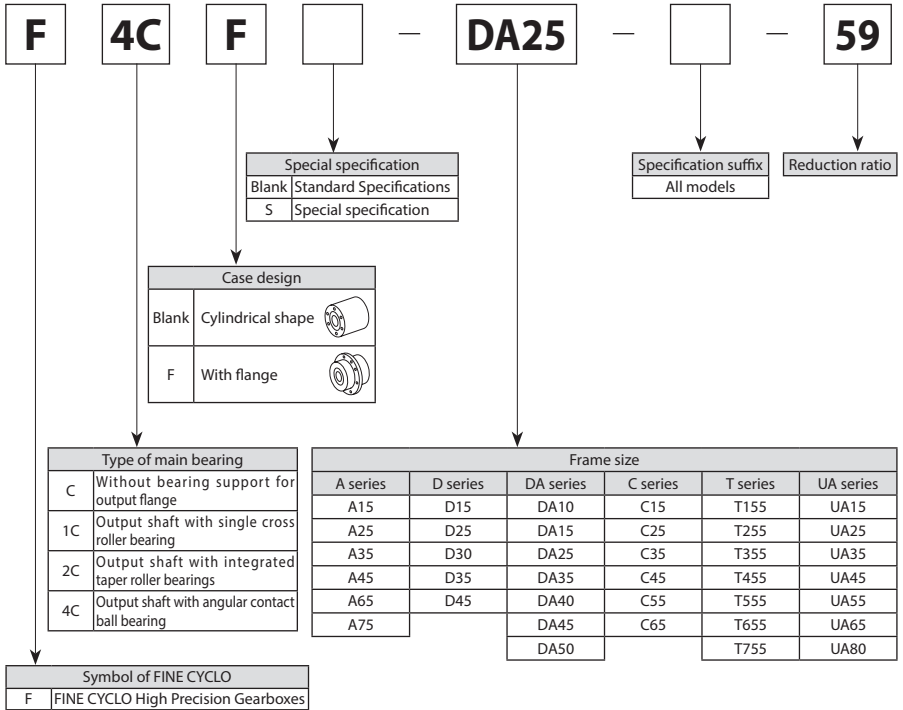

When storing reducers for any extended period of time, consider the following important points.

2-1 Storage Location

Store the unit indoors in a clean dry location.

Do not store the unit outdoors or in locations where there is excessive moisture, dust, severe temperature change, corrosive gas, etc.

2-2 Storage Period

- Storage period should be less than 1 year.
- Standard Rust Prevention Specifications

External rust prevention Standard specification is no coating. The unit is packaged with volatile rustproof paper, however, the surface condition should be checked for rust on the machined surfaces 6 months after shipment. When long-term storage is necessary, rust prevention such as application of rust prevention oil should be performed.

Internal rust prevention The unit should generally be stored inside a factory or warehouse in an environment that is free from moisture, dust, severe temperature change, corrosive gas, etc.

- When the unit will be shipped overseas or stored for a period of longer than 1 year, please contact us for special rust prevention specifications.
- When the unit will be stored for a period of longer than 1 year, the unit should be operated for a few minutes under no-load conditions every two or three months.

2-3 Use After Storage

- The oil seal is prone to deterioration due to the surrounding conditions such as temperature, ultraviolet rays, etc., so after long-term storage, the unit should be inspected before operation, and any deteriorated parts should be replaced with new parts.
- When the storage period is 2 years or longer, the oil seals and grease should be replaced before starting operation.
- At the start of operation, make sure there is no abnormal noise, vibration, heat, etc. If any abnormality is found, immediately contact the nearest agent, dealer or our sales office.

【3】 Transportation

DANGER

- Do not stand directly under a unit suspended by a crane or other lifting mechanism; otherwise, injury or death may result.

CAUTION

- Exercise ample care so as not to drop or tip over the unit during transportation.
- When lifting the unit using eye bolts in the threaded holes provided on the main unit, refer to the package, exterior drawings, catalog, etc., and do not lift a unit that is heavier than the rated load of the eye bolts; otherwise, the falling/tumbling of the unit or damage to the lifting devices may cause personal injury or equipment damage.
- After the unit has been mounted in the machine, avoid lifting the entire machine with using the eye bolts; otherwise, it may result in injury or damage to the equipment due to the unit falling or tipping over, or due to failure of the eye bolts.
- Use proper lifting fixtures, and make sure the eye bolts and nuts are not loose before lifting.

CAUTION

- Do not use the unit for a purpose other than that indicated on the nameplate or in the manufacturing specifications; otherwise, injury or damage to the equipment may result.
- Do not place any object that will hinder ventilation around the reducer; otherwise, the cooling effect is reduced, possibly leading to fire or burns due to excessive heat built-up.
- Absolutely do not stand on or hang from the unit; otherwise, injury or damage to the equipment may result.
- Do not touch the keyways of the unit with bare hands; otherwise, injury may result.
- When the unit is used in food processing applications, machines for cleanroom and so on, vulnerable to oil contamination, install an oil pan or other such device to cope with grease leakage due to breakdown or failure; otherwise, grease leakage may cause failure of the unit, etc.

4-1 Place of Installation

Ambient temperature -10 to 40°C (Start failure may occur depending on the speed and torque of the motor in use, so consult us if the reducer will be used at about -10 to 0°C.)

Ambient humidity 85%RH or less. No condensation.

Altitude 1000m max.

Ambient atmosphere There should be no corrosive gas, combustible gas, or steam.
The location should be free from dust and well ventilated.

Installation Indoor (Free from dust, water, other liquids)

- Mounting in conditions other than the above requires adherence to special specifications. Please consult with us.
- Mount in a location that enables easy operation, such as inspection and maintenance.
- Mount on a sufficiently rigid member.

4-2 Installation Angle

There is no limit on a mounting angle.

In some models, the amount of grease required may change depending on the mounting direction. For details, refer to P9-14.

[5] Lubrication

DANGER

- For models that have not been lubricated with grease, be sure to lubricate with the recommended grease before operation. Operating the unit without lubricating with the proper grease could result in failure of the equipment caused by damage to the internal parts of the reducer, and locking of the reducer.
- Be sure to use the recommended lubricating grease. If grease other than the recommended grease is used, not only will the performance and life of unit be greatly decreased, but failure of the equipment could occur due to damage to the internal parts of the reducer, and locking of the reducer.

CAUTION

- Further adding grease to models that have already be greased may cause heat generation or grease leakage to occur.
- Excessive grease filling causes rise in the internal pressure, which causes heat generation, grease leak and oil seal detachment.
Insufficient grease will cause improper lubrication, resulting in damage to the parts.
- Dispose of the reducer as general industrial waste.

5-1 Grease

- Depending on the specifications for use, the actual grease used may differ from the listed grease, so be sure to check the delivery specifications.
- As a guide, change the grease and perform maintenance with disassembly of the equipment after every 20,000 hours of operation or every 3 to 5 years. In the case of maintenance with disassembly, please contact the nearest agent, dealer or sales office.

■ A Series

The unit is filled with grease before shipment, so the unit can be used as is.

Table 5-1 Recommended grease

Product Name	Manufacturer	Ambient temperature
Citrax FA No.2	Kyodo Yushi Co., Ltd.	-10 to 40°C

■ D Series with servo motor adapter

The unit is filled with grease before shipment, so the unit can be used as is.

Table 5-2 Recommended grease

Product Name	Manufacturer	Ambient temperature
Multemp FZ No.00	Kyodo Yushi Co., Ltd.	-10 to 40°C

■ C Series

The unit is filled with grease before shipment, so the unit can be used as is.

Table 5-3 Recommended grease

Product Name	Manufacturer	Ambient temperature
Multemp FZ No.00	Kyodo Yushi Co., Ltd.	-10 to 40°C

■ D Series (Except for models with a servo motor adapter)

- Always lubricate with the recommended grease before operation.
- The recommended grease may not same as shown in the table below depending on the specifications, so check the delivery specifications.
- The actual amount of grease used varies depending on differences in structure, etc. Even in cases where the amount indicated below is supplied, there may be an excess or deficiency in the filling amount, so be sure to always check the grease level.

Table 5-4 Recommended grease

Product Name	Manufacturer	Ambient temperature
Multemp FZ No.00	Kyodo Yushi Co., Ltd.	-10 to 40°C

Table 5-5 Grease filling quantity (g)

Frame size	D15	D25	D30	D35	D45
Vertical mounting (1) (Output flange is downward)	55	100	220	190	320
Vertical mounting (2) (Output flange is upward)	40	45	85	150	260
Horizontal mounting	50	95	200	160	270

- For horizontal mounting, align the output grease fill/drain port with the position of dimension A (refer to Table 5-6).
- When filling grease for the first time, use the lower grease fill/drain port, and thoroughly fill grease into the reducer.

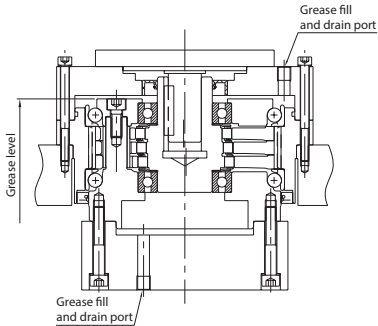

Fig. 5-1 Vertical mounting (1)
(Output flange is downward)

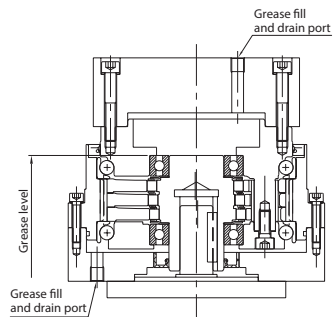

Fig. 5-2 Vertical mounting (2)
(Output flange is upward)

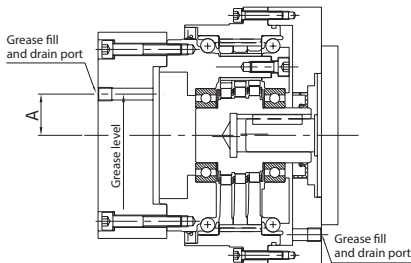

Fig. 5-3 Horizontal mounting

Table 5-6 Position of output fill/drain port in horizontal mounting (mm)

Frame size	Dimension A
D15	20
D25	26
D30	29
D35	34
D45	39

[5] Lubrication

■ DA Series

- Always lubricate with the recommended grease before operation.
- The recommended grease may not same as shown in the table below depending on the specifications, so check the delivery specifications.
- The actual amount of grease used varies depending on differences in structure, etc. Even in cases where the amount indicated below is supplied, there may be an excess or deficiency in the filling amount, so be sure to always check the grease level.

Table 5-7 Recommended grease

Product Name	Manufacturer	Ambient temperature
Multemp FZ No.00	Kyodo Yushi Co., Ltd.	-10 to 40°C

Table 5-8 Grease filling quantity (g)

Frame size	DA10	DA15	DA25	DA35	DA40	DA45	DA50
Vertical mounting (1) (Output flange is downward)	35	52	113	196	204	222	305
Vertical mounting (2) (Output flange is upward)							
Horizontal mounting	35	39	91	161	170	178	252

- For horizontal mounting, align the output grease fill/drain port with the position of dimension A (refer to Table 5-9).
- When filling grease for the first time, use the lower grease fill/drain port, and thoroughly fill grease into the reducer.
- Table 5-8 indicates the amount of grease to be filled in the reducer drive space. Grease must also be supplied to the device-side space ([1], [2]).

(1) Vertical mounting (1) (Output flange is downward)

- Supply grease to the reducer drive space.
- Supply grease equal to the volume to the device-side space [2].
- To prevent an increase in internal pressure, secure a space equal to 10 to 20% of the total volume (reducer drive space + device-side space [1] + device-side space [2]) for the device-side space [1].

(2) Vertical mounting (2) (Output flange is upward)

- Supply grease to the reducer drive space.
- Supply grease equal to the volume to the device-side space [1].
- To prevent an increase in internal pressure, secure a space equal to 10 to 20% of the total volume (reducer drive space + device-side space [1] + device-side space [2]) for the device-side space [2].

(3) Horizontal mounting

- Supply grease to the reducer drive space.
- Fill about 70% to 80% of the volume of device-side space [1], [2] with grease.

[5] Lubrication

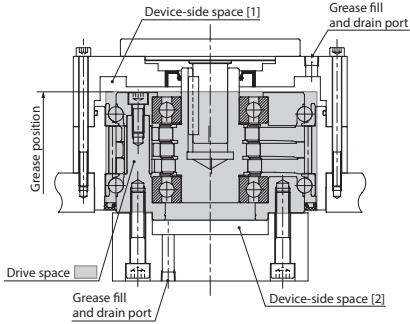

Fig. 5-4 Vertical mounting (1)
(Output flange is downward)

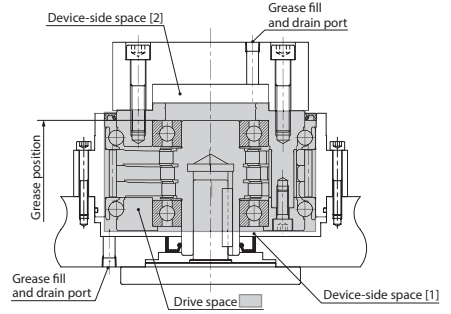

Fig. 5-5 Vertical mounting (2)
(Output flange is upward)

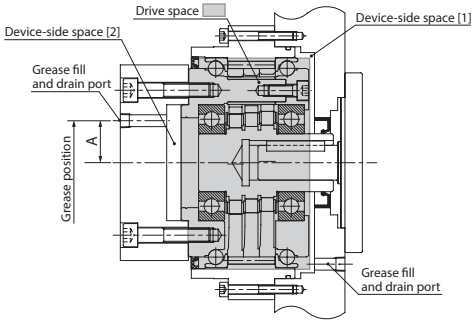

Fig. 5-6 Horizontal mounting

Table 5-9 Position of output fill/drain port in horizontal mounting (mm)

Frame size	Dimension A
DA10	15
DA15	20
DA25	27
DA35	34
DA40	36
DA45	39
DA50	43

[5] Lubrication

■ T Series

- Always lubricate with the recommended grease before operation.
- The recommended grease may not same as shown in the table below depending on the specifications, so check the delivery specifications.
- The actual amount of grease used varies depending on differences in structure, etc. Even in cases where the amount indicated below is supplied, there may be an excess or deficiency in the filling amount, so be sure to always check the grease level.

Table 5-10 Recommended grease

Product Name	Manufacturer	Ambient temperature
Multemp FZ No.00	Kyodo Yushi Co., Ltd.	-10 to 40°C
Sell Alvania EP Grease R0	Shell Lubricants Japan	

Table 5-11 Grease filling quantity (g)

Frame size	T155	T255	T355	T455	T555	T655	T755
Vertical mounting (1) (Output flange is downward)	80	120	230	300	400	700	800
Vertical mounting (2) (Output flange is upward)							
Horizontal mounting	60	100	180	240	320	560	640

- Align the output grease fill/drain port with the position of dimension A on the eccentric planetary shaft (refer to Table 5-12).
- When filling grease for the first time, use the lower grease fill/drain port, and thoroughly fill grease into the reducer.

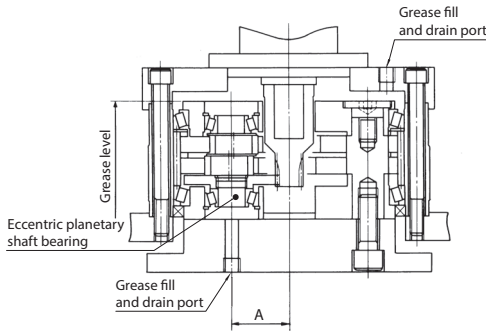

Fig. 5-7 Vertical mounting (1)
(Output flange is downward)

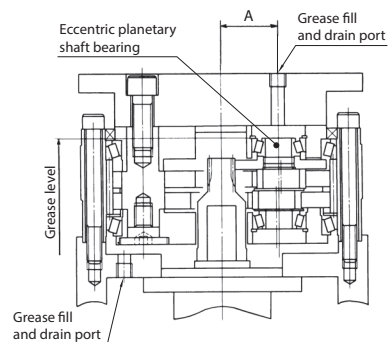

Fig. 5-8 Vertical mounting (2)
(Output flange is upward)

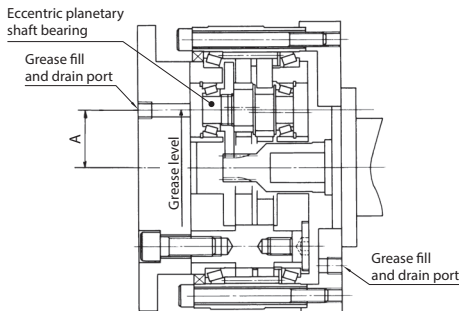

Fig. 5-9 Horizontal mounting

Table 5-12 Output grease fill/drain port (mm)

Frame size	Dimension A
T155	25
T255	31
T355	39
T455	47
T555	55
T655	63
T755	72

■ UA Series

- Always lubricate with the recommended grease before operation.
- The recommended grease may not same as shown in the table below depending on the specifications, so check the delivery specifications.
- The actual amount of grease used varies depending on differences in structure, etc. Even in cases where the amount indicated below is supplied, there may be an excess or deficiency in the filling amount, so be sure to always check the grease level.

Table 5-13 Recommended grease

Product Name	Manufacturer	Ambient temperature
Multemp FZ No.00	Kyodo Yushi Co., Ltd.	-10 to 40°C

Table 5-14 Reducer drive space grease filling amount (g)

Frame size	UA15	UA25	UA35	UA45	UA55	UA65	UA80
Vertical mounting (1) (Output flange is downward)	152	261	400	487	818	1180	2140
Vertical mounting (2) (Output flange is upward)	143	227	361	417	748	1090	1995
Horizontal mounting	122	209	313	383	679	940	1700

- Align the output grease fill/drain port with the position of dimension A on the eccentric planetary shaft (refer to Table 5-15).
- When filling grease for the first time, use the lower grease fill/drain port, and thoroughly fill grease into the reducer.
- Table 5-14 indicates the amount of grease to be filled in the reducer drive space. It is also necessary to fill grease to the device-side space ([1], [4]).

(1) Vertical mounting (1) (Output flange is downward)

- Supply grease to the reducer drive space.
- To prevent an increase in internal pressure, secure a space equal to 10 to 20% of the total volume (reducer drive space + device-side space [2]) for the device-side space [2].

(2) Vertical mounting (2) (Output flange is upward)

- Supply grease to the reducer drive space.
- Supply grease equal to the volume to the device-side space [4].
- To prevent an increase in internal pressure, secure a space equal to 10 to 20% of the total volume (reducer drive space + device-side space [3] + device-side space [4]) for the device-side space [3].

(3) Horizontal mounting

- Supply grease to the reducer drive space.
- Supply grease equal to 70 to 80% the volume of [1] to the device-side space [1].

[5] Lubrication

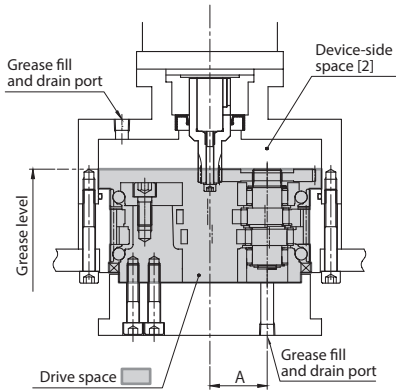

Fig. 5-10 Vertical mounting (1)
(Output flange is downward)

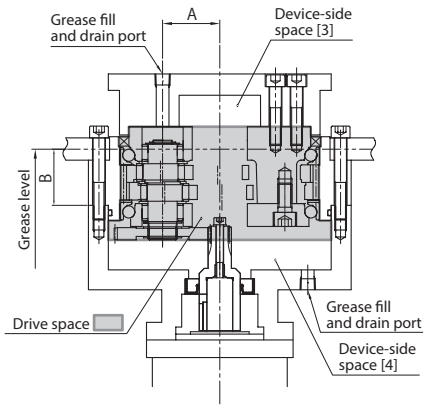

Fig. 5-11 Vertical mounting (2)
(Output flange is upward)

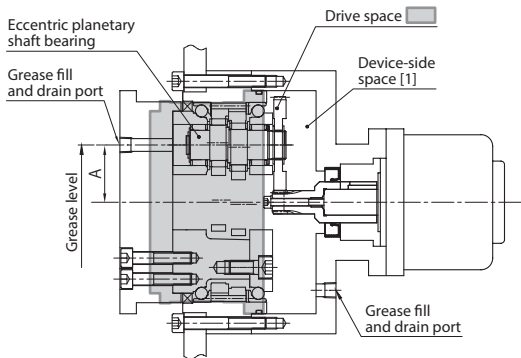

Fig. 5-12 Horizontal mounting

Table 5-15 Output grease fill/drain port (mm)

Frame size	Dimension A
UA15	29
UA25	34
UA35	39
UA45	49
UA55	54
UA65	63
UA80	71

Table 5-16 Vertical mounting grease level (mm)

Frame size	Dimension B
UA15	33
UA25	34
UA35	45
UA45	50
UA55	65
UA65	74
UA80	75

[6] Coupling with Other Machines

CAUTION

- Confirm the direction of rotation before coupling with the driven machine; otherwise, injury or damage to the equipment may result.
- Provide a cover etc. so that the rotating part cannot be touched; otherwise, injury may result.
- When coupling the reducer with a load, check that the centering, belt tension, parallelism of the pulleys, etc. are within the specified limits. When the unit is directly coupled with another machine, check that the direct coupling accuracy is within the specified limits. When a belt is used for coupling the unit with another machine, check the belt tension. Correctly tighten bolts on the pulley and coupling before operation; otherwise, injury may result because of misalignment.
- Make sure to use the designated number of bolts and tightening torque, when fixing the ring gear housing to the output flange. Reducer may not function optimally when fixed with improper number of bolts or tightening torque.

6-1 Coupling Installation

- When installing a coupling, do not apply an impact force or excessive thrust to the output flange or shaft; otherwise, the bearing may be damaged.
- When chain sprockets, gears or pullers are coupled with the reducer, please use within the range of the allowable radial axial load, or shaft and bearing may be damaged.

[6] Coupling with Other Machines

6-2 Speed Ratio and Rotation Direction

The rotation direction and speed ratio are as illustrated in Fig. 6-1 to 6-3 depending on the fixed, input, and output locations.

- i : Speed ratio (= [Output speed]/[Input speed]) *"-1" indicates opposite direction.
+ of the speed ratio i indicate that the input and output are in the same and opposite directions, respectively.
- n : Reduction ratio.

■ A Series, D Series, DA Series, C Series

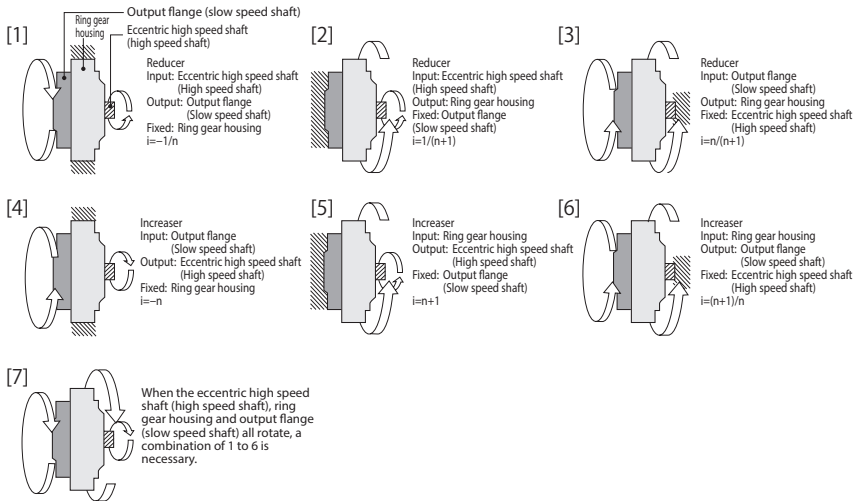

Fig. 6-1 Direction of rotation and speed ratio (A series, D series, DA series, C series)

■ T Series

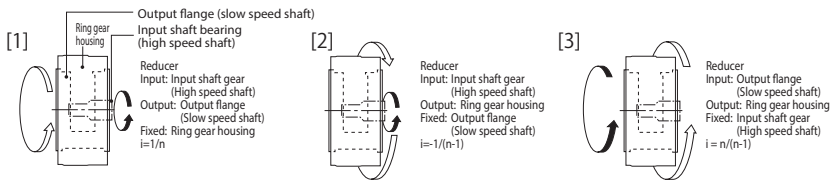

Figure 6-2 Speed Ratio and Rotation Direction (T series)

■ UA Series

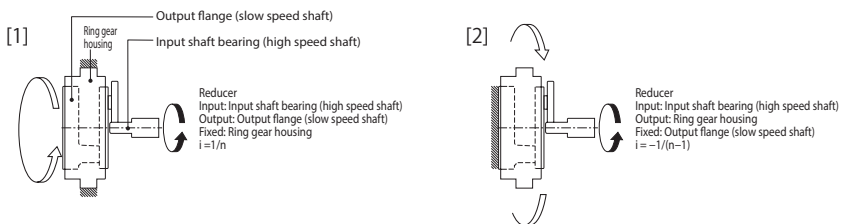

Figure 6-3 Speed Ratio and Rotation Direction (UA series)

[6] Coupling with Other Machines

6-3 Keyless Shaft Motor Assembly (D Series With Servo Motor Adapter)

- [1] Remove the oil and dust inside the motor shaft and eccentric high speed shaft. (Rust-prevention oil is applied to the inside of the eccentric high speed shaft before shipping.)
- [2] Place the reducer on a suitable base so that the output flange is facing down.
- [3] Align the notches on the eccentric high speed shaft and clamp ring.)
- [4] Remove the cap on the adapter plate, and insert a hex wrench from the set hole into the hex socket head bolt. In that state, insert the motor shaft into the eccentric high speed shaft.
- [5] When assembling the motor and CYCLO reducer, make sure that center of the both shafts are aligned. Do not forcibly assemble in a state where the shafts are inclined or misaligned.
- [6] Tighten the motor and adapter plate with the motor mounting bolts. Before tightening make sure that the spigot of the motor is securely in the spigot of the adapter plate. If the bolts are tightened in a state where the spigots are not joined, tightening will be one sided and may damage the internal bearings, etc.
- [7] Tighten the hex socket head bolt of the clamp ring to the torque indicated in Table 6-1.
- [8] After operating at low speed, re-tighten the bolt to the torque indicated in Table 6-1.
- [9] Attach the removed adapter plate cap.

Table 6-1 Tightening torque for the hex socket head bolt of the clamp ring

Size of bolts	M5	M6	M8	M10
Tightening torque (N · m)	5.5	9.6	23	46

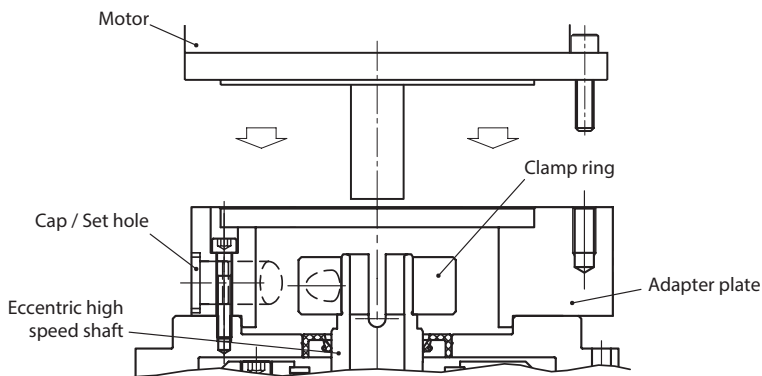

Fig. 6-4 Assembly drawing

[6] Coupling with Other Machines

6-4 Assembly Procedure

■ A Series FC Type

[1]

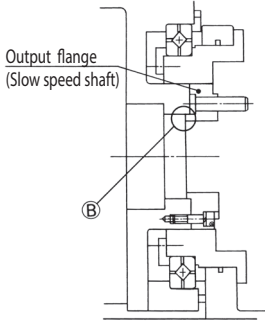

- Attach the CYCLO output flange to the output shaft of the device with bolts. (Spigot B)

[2]

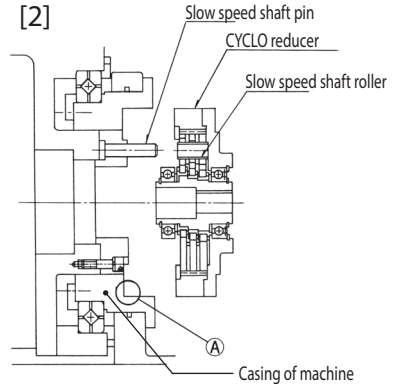

- Align the phase of the slow speed shaft pin of the output flange with the slow speed shaft roller of the reducer, and attach the reducer to the machine casing. (Spigot A)

When attaching the reducer to the machine casing, be sure to assemble the reducer with the slow speed shaft roller to the output flange, otherwise the ring (refer to P35) may be damaged.

[3]

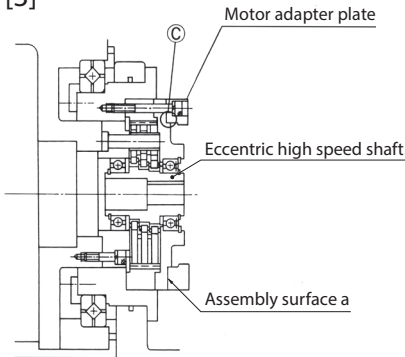

- Adjust the phase of the reducer and machine casing bolt holes by rotating the eccentric high speed shaft with the output-flange fixed.
- Fix the reducer part to the casing of machine with bolts.
- When mounting the motor adapter plate, apply liquid gasket to the assembly surface a, and fasten the motor adapter plate and the reducer to the machine casing with bolts. (Spigot C)

[4]

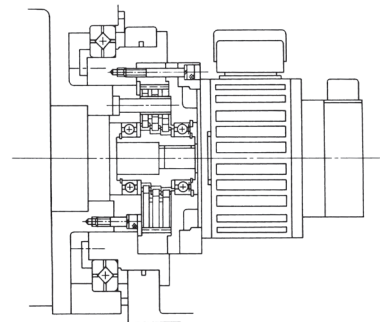

- Apply an anti-fretting agent to the motor shaft.
- Align the key phases of the motor shaft and the eccentric high speed shaft, and fasten the motor to the reducer with bolts.

Fig. 6-5 Assembly procedure A series FC type

[6] Coupling with Other Machines

Table 6-2 Mounting bolts A series FC type

Frame size	Tightening of the output flange		Tightening of the reducer part	
	Bolt Number and size	Bolt tightening torque N·m	Bolt Number and size	Bolt tightening torque N·m
A15	12-M5	9.32	8-M5	9.32
A25	12-M6	15.7	8-M6	15.7
A35	12-M8	38.3	8-M8	38.3
A45	12-M10	76.5	12-M8	38.3
A65	12-M12	133	12-M10	76.5
A75	12-M12	133	12-M10	76.5

- Bolt: Hexagon socket head bolts of strength class 12.9 of JIS B 1176.
- Seat scratching measures: Spring washer (JIS B 1251, 2 types)
- Locking measure: adhesive (Loctite 262, etc) in addition to conical spring washers
- Recommended liquid gasket: ThreeBond Co., Ltd., Liquid gasket ThreeBond 1215

[6] Coupling with Other Machines

■ A series F1C type (assembly example 1)

[1]

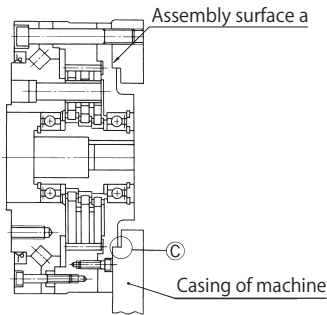

- Apply liquid gasket to the assembly surface and fix the FINE CYCLO to the casing of machine with bolts. (Spigot ©)
(In this assembly example, the casing of machine and motor adapter are shared.)

[2]

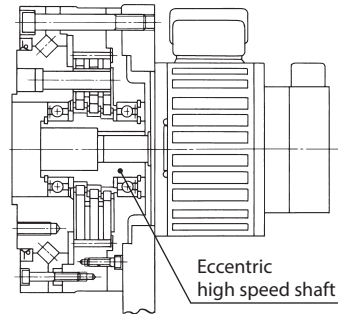

- Apply anti-fretting agent to the motor shaft.
- Align the key phase of the motor shaft and the high speed shaft and fix the motor to the FINE CYCLO with bolts.

[3]

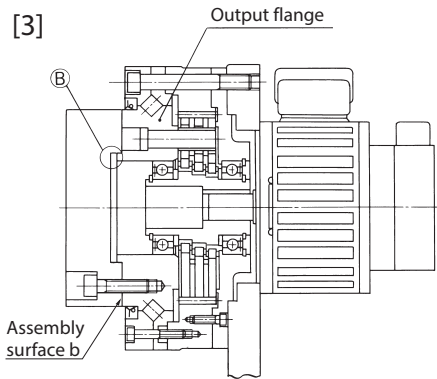

- Apply liquid gasket to the assembly surface b, and fasten the output flange to the output shaft of the machine with bolts. (Spigot ©)

Fig. 6-6 Assembly procedure A series F1C type (assembly example 1)

[6] Coupling with Other Machines

■ A series F1C type (assembly example 2)

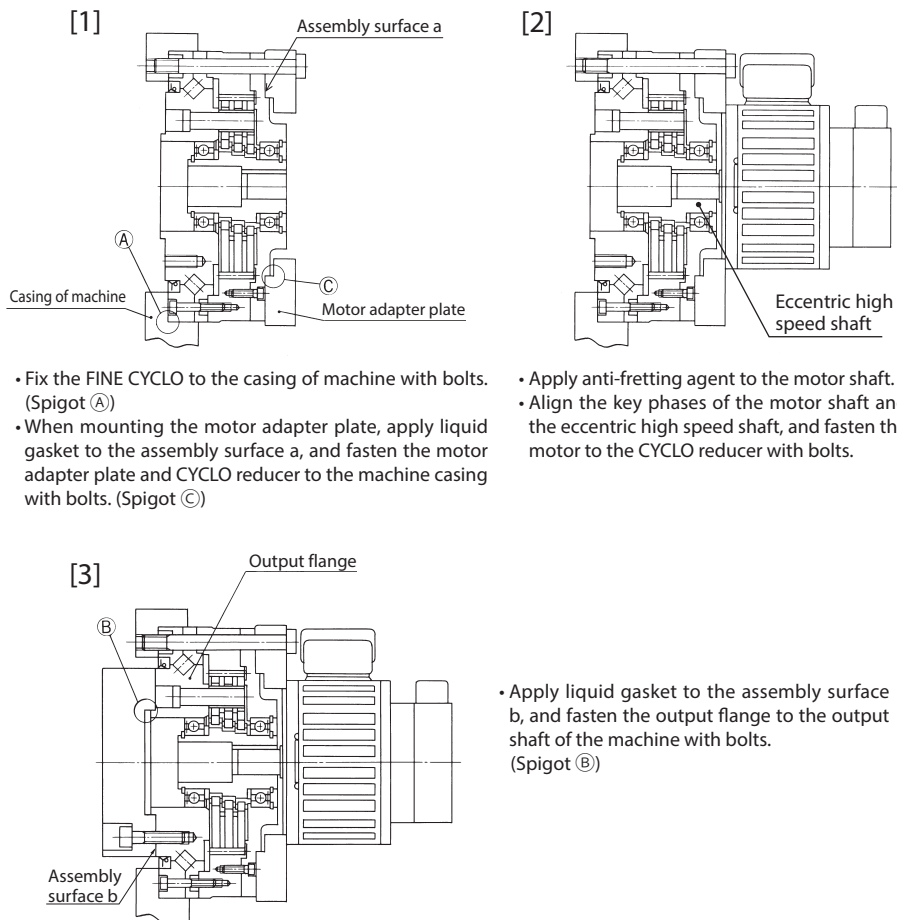

- Fix the FINE CYCLO to the casing of machine with bolts. (Spigot (A))
- When mounting the motor adapter plate, apply liquid gasket to the assembly surface a, and fasten the motor adapter plate and CYCLO reducer to the machine casing with bolts. (Spigot (C))

- Apply anti-fretting agent to the motor shaft.
- Align the key phases of the motor shaft and the eccentric high speed shaft, and fasten the motor to the CYCLO reducer with bolts.

- Apply liquid gasket to the assembly surface b, and fasten the output flange to the output shaft of the machine with bolts. (Spigot (B))

Fig. 6-7 Assembly procedure A series F1C type (assembly example 2)

Table 6-3 Mounting bolts A series F1C type (for assembly examples 1 and 2)

Frame size	Tightening of the output flange		Tightening of the reducer part	
	Bolt Number and size	Bolt tightening torque N · m	Bolt Number and size	Bolt tightening torque N · m
A15	12-M6	15.7	12-M6	15.7
A25	12-M8	38.3	12-M8	38.3
A35	12-M10	76.5	12-M10	76.5

- Bolt: Hexagon socket head bolts of strength class 12.9 of JIS B 1176.
- Seat scratching measures: Spring washer (JIS B 1251, 2 types)
- Locking measure: Adhesive (Loctite 262, etc) in addition to conical spring washers
- Recommended liquid gasket: ThreeBond Co., Ltd., Liquid gasket ThreeBond 1215

[6] Coupling with Other Machines

■ A series F2C type (assembly example 1)

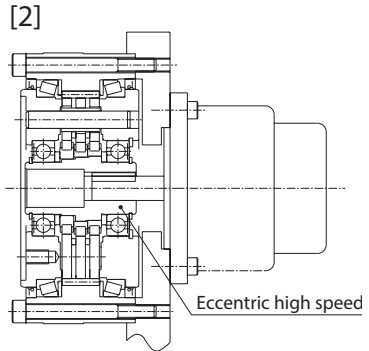
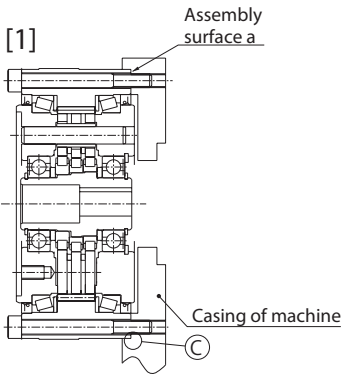

- Apply liquid gasket to the assembly surface a, and fix the FINE CYCLO to the casing of machine with bolts. (Spigot ©)
- (In this assembly example, the casing of machine and motor adapter are shared.)

- Apply anti-fretting agent to the motor shaft.
- Align the key phases of the motor shaft and the eccentric high speed shaft, and fasten the motor to the CYCLO reducer with bolts.

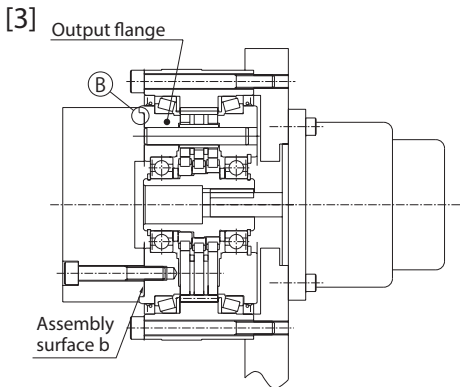

- Apply liquid gasket to the assembly surface b, and fasten the output flange to the output shaft of the machine with bolts. (Spigot ©)

Fig. 6-8 Assembly procedure A series F2C type (assembly example 1)

[6] Coupling with Other Machines

■ A series F2C type (assembly example 2)

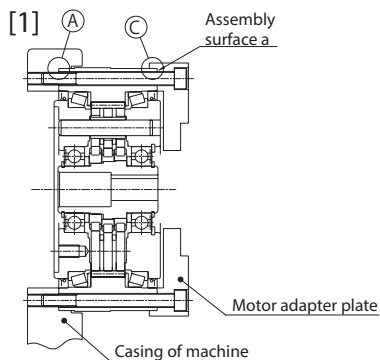

- Fix the FINE CYCLO to the casing of machine with bolts. (Spigot (A))
- When mounting the motor adapter plate, apply liquid gasket to the assembly surface a, and fasten the motor adapter plate and CYCLO reducer to the machine casing with bolts. (Spigot (C))

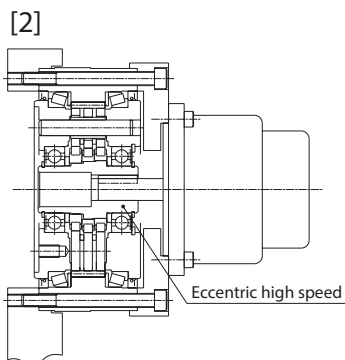

- Apply anti-fretting agent to the motor shaft.
- Align the key phases of the motor shaft and the eccentric high speed shaft, and fasten the motor to the CYCLO reducer with bolts.

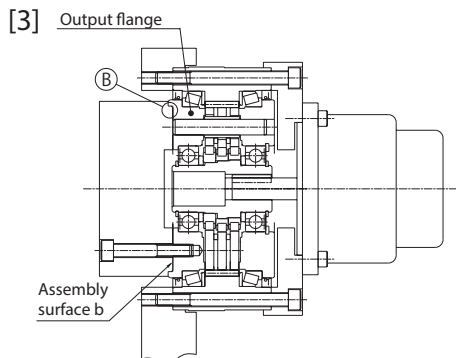

- Apply liquid gasket to the assembly surface b, and fasten the output flange to the output shaft of the machine with bolts. (Spigot (B))

Fig. 6-9 Assembly procedure A series F2C type (assembly example 2)

Table 6-4 Mounting bolts A series F2C type (for assembly examples 1 and 2)

Frame size	Tightening of the output flange		Tightening of the reducer part	
	Bolt Number and size	Bolt tightening torque N · m	Bolt Number and size	Bolt tightening torque N · m
A15	12-M6	15.7	16-M6	12.8
A25	12-M8	38.3	12-M8	31.4
A35	12-M10	76.5	16-M8	31.4
A45	12-M14	206	12-M12	107

- Bolt: Hexagon socket head bolts of strength class 12.9 of JIS B 1176.
- Seat scratching measures: Spring washer (JIS B 1251, 2 types)
- Locking measure: Adhesive (Loctite 262, etc) in addition to conical spring washers
- Recommended liquid gasket: ThreeBond Co., Ltd., Liquid gasket ThreeBond 1215

[6] Coupling with Other Machines

■ D Series, DA Series (assembly example 1)

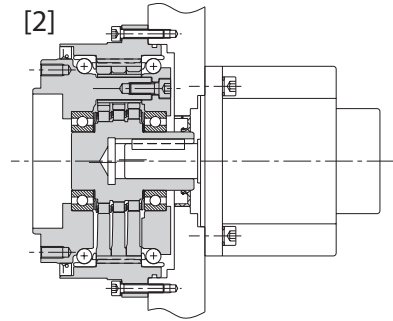
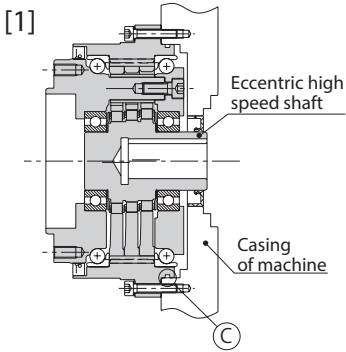

- Fix the FINE CYCLO to the casing of machine with bolts. (Spigot ©)
- (In this assembly example, the casing of machine and motor adapter are shared.)
- Use a seal structure between the motor adapter and the eccentric high speed shaft.)

- Apply anti-fretting agent to the motor shaft.
- Align the key phases of the motor shaft and the eccentric high speed shaft, and fasten the motor to the CYCLO reducer with bolts.

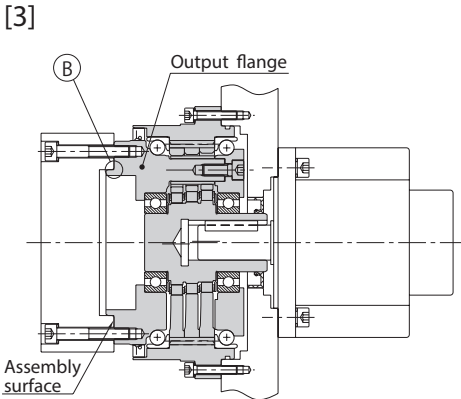

- Apply liquid gasket to the assembly surface and attach the output flange to the output shaft of the machine with bolts. (Spigot ©)

Fig. 6-10 Assembly procedure D series, DA series (assembly example 1)

[6] Coupling with Other Machines

■ D Series, DA Series (assembly example 2)

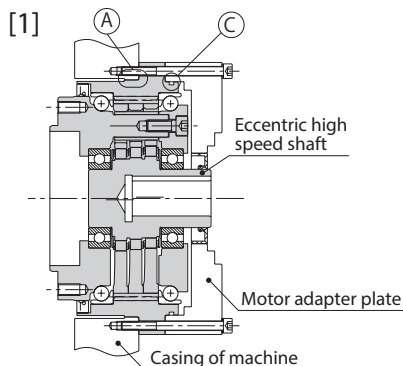

- Fix the FINE CYCLO to the casing of machine with bolts. (Spigot A)
- When mounting the motor adapter plate, fasten the motor adapter plate and the CYCLO reducer to the machine casing with bolts. (Spigot C)
(Use a seal structure between the motor adapter and the eccentric high speed shaft.)

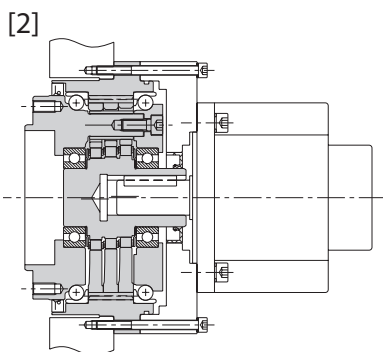

- Apply anti-fretting agent to the motor shaft.
- Align the key phases of the motor shaft and the eccentric high speed shaft, and fasten the motor to the CYCLO reducer with bolts.

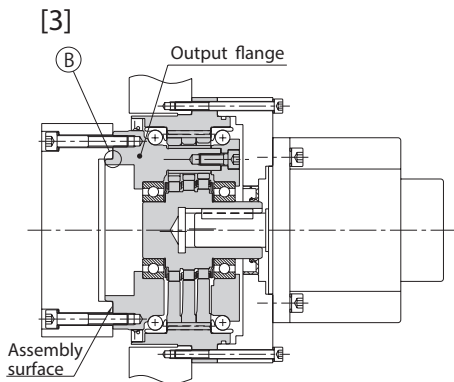

- Apply liquid gasket to the assembly surface and attach the output flange to the output shaft of the machine with bolts. (Spigot B)

Fig. 6-11 Assembly procedure D series, DA series (assembly example 2)

Table 6-5 Mounting bolts D series(for assembly examples 1 and 2)

Frame size	Tightening of the output flange		Tightening of the reducer part	
	Bolt Number-size	Bolt tightening torque N · m	Bolt Number and size	Bolt tightening torque N · m
D15	12-M8	38.3	12-M6	15.7
D25	12-M8	38.3	16-M6	15.7
D30	16-M8	38.3	16-M6	15.7
D35	12-M10	76.5	16-M8	38.3
D45	16-M12	133	16-M10	76.5
DA10	12-M6	15.7	16-M4	4.6
DA15	12-M8	38.3	16-M5	9.1
DA25	18-M8	38.3	16-M6	15.7
DA35	16-M10	76.5	16-M8	38.3
DA40	16-M10	76.5	18-M8	38.3
DA45	18-M10	76.5	16-M10	76.5
DA50	18-M12	133	16-M10	76.5

- Bolt:
Hexagon socket head bolts of strength class 12.9 of JIS B 1176
- Seat scratching measures:
Spring washer (JIS B 1251, 2 types)
- Locking measure:
Adhesive (Loctite 262, etc) in addition to conical spring washers
- Recommended liquid gasket:
ThreeBond Co., Ltd., Liquid gasket ThreeBond 1215

[6] Coupling with Other Machines

■ C Series

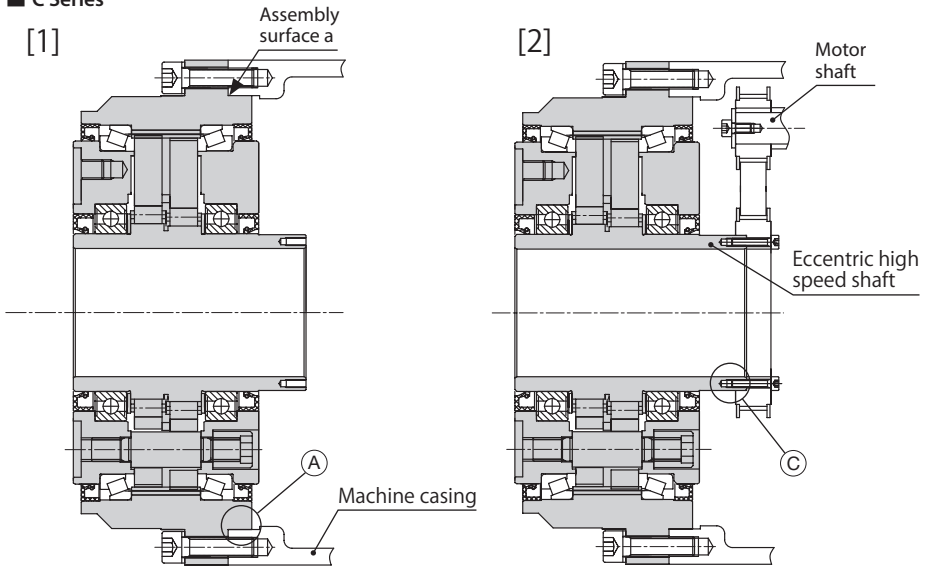

• Apply liquid gasket to the assembly surface a as necessary, and fasten the CYCLO reducer to the machine casing with bolts. (Spigot A)

• Fasten the pulleys and other input members to the eccentric high speed shaft with bolts. (Spigot C)

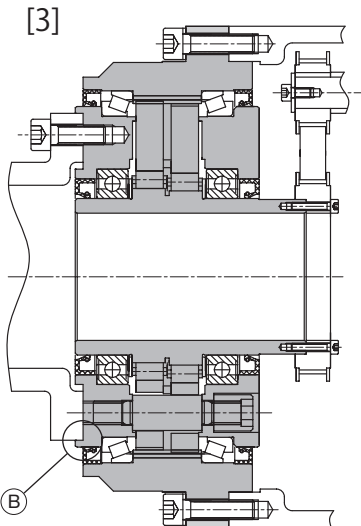

• Attach the output flange to the output shaft of the device with bolts. (Spigot B)

Table 6-6 Mounting bolts C series

Frame size	Tightening of the output flange		Tightening of the reducer part	
	Bolt Number and size	Bolt tightening torque N·m	Bolt Number and size	Bolt tightening torque N·m
C15	16-M6	13.6	12-M6	13.6
C25	12-M8	33.4	12-M8	33.4
C35	12-M10	65.7	8-M10	65.7
C45	12-M12	114	8-M12	114
C55	12-M14	181	12-M12	114
C65	12-M16	284	16-M12	114

Frame size	Tightening of the eccentric high speed shaft	
	Bolt Number and size	Bolt tightening torque N·m
C15	6-M3	1.67
C25	6-M3	1.67
C35	6-M4	3.92
C45	6-M4	3.92
C55	8-M5	8.04
C65	12-M5	8.04

- Bolt: Hexagon socket head bolts of strength class 10.9 of JIS B 1176.
- Seat scratching measures: Spring washer (JIS B 1251, 2 types)
- Locking measure: adhesive (Loctite 262, etc) in addition to conical spring washers
- Recommended liquid gasket: ThreeBond Co., Ltd., Liquid gasket ThreeBond 1215

Fig. 6-12 Assembly procedure C series

[6] Coupling with Other Machines

■ T Series (assembly example 1)

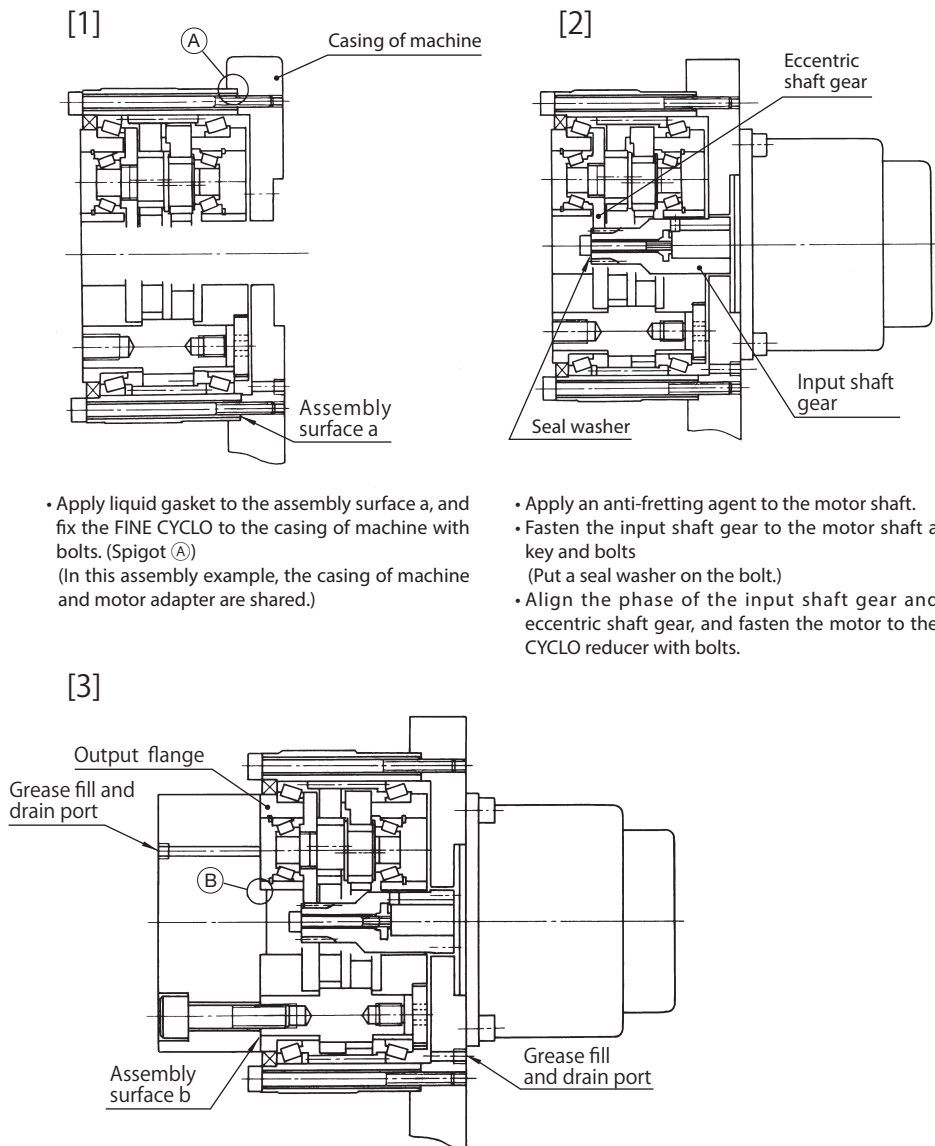

- Apply liquid gasket to the assembly surface a, and fix the FINE CYCLO to the casing of machine with bolts. (Spigot ①)
(In this assembly example, the casing of machine and motor adapter are shared.)

- Apply an anti-fretting agent to the motor shaft.
- Fasten the input shaft gear to the motor shaft a key and bolts
(Put a seal washer on the bolt.)
- Align the phase of the input shaft gear and eccentric shaft gear, and fasten the motor to the CYCLO reducer with bolts.

- Apply liquid gasket to the assembly surface b, and fasten the output flange to the output shaft of the machine with bolts. (Spigot ②)
- Fill the grease from the machine casing grease fill/drain port (refer to P12), and close each grease fill/drain port.

Fig. 6-13 Assembly procedure T series (assembly example 1)

[6] Coupling with Other Machines

■ T Series (assembly example 2)

[1]

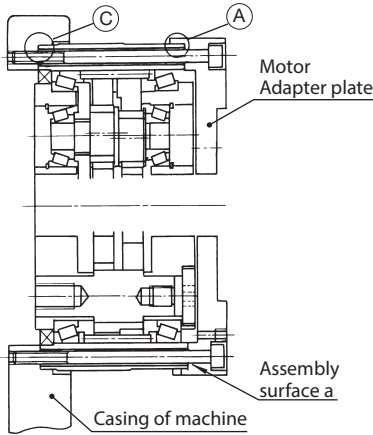

[2]

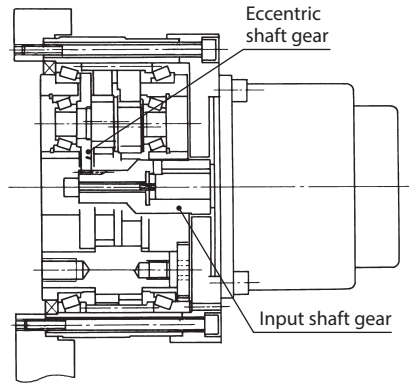

- Apply liquid gasket to the assembly surface a, and fasten the motor adapter plate and CYCLO reducer to the machine casing with bolts. (Spigot (A), (C))

- Apply an anti-fretting agent to the motor shaft.
- Fasten the input shaft gear to the motor shaft a key and bolts (Put a seal washer on the bolt.)
- Align the phase of the input shaft gear and eccentric shaft gear, and fasten the motor to the CYCLO reducer with bolts.

[3]

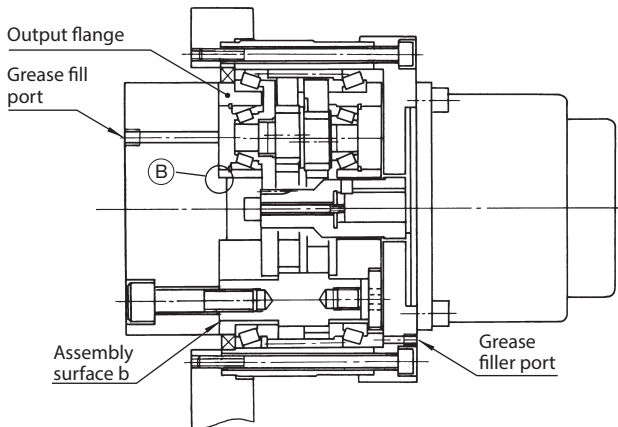

- Apply liquid gasket to the assembly surface b, and fasten the output flange to the output shaft of the machine with bolts. (Spigot (B))
- Fill the grease from the machine casing grease fill/drain port (refer to P12), and close each grease fill/drain port.

Fig. 6-14 Assembly procedure T series (assembly example 2)

[6] Coupling with Other Machines

Table 6-7 Mounting bolts T series (for assembly examples 1 and 2)

Frame size	Tightening of the output flange				Tightening of the reducer part		
	Threaded hole (Fig. 6-11)	Bolt Number and size	Bolt PCD mm	Bolt tightening torque N·m	Bolt Number and size	Bolt PCD mm	Bolt tightening torque N·m
T155	*1	6-M8	72	31.4	16-M6	114	12.8
	*3	Note: 3-M8	66	31.4			
	*2	6-M6	45	12.8			
T255	*1	6-M12	84	107	12-M8	142	31.4
	*3	Note: 3-M8	82	31.4			
	*2	6-M8	50	31.4			
T355	*1	6-M14	104	172	16-M8	171	31.4
	*3	Note: 3-M12	102	107			
	*2	6-M12	63	107			
T455	*1	6-M16	135	265	12-M12	210	107
	*3	Note: 3-M12	129	107			
	*2	6-M12	93	107			
T555	*1	6-M18	165	363	16-M12	240	107
	*3	Note: 3-M14	150	172			
	*2	6-M14	115	172			
T655	*1	6-M22	180	706	16-M14	272	172
	*3	Note: 3-M16	170	265			
	*2	6-M16	115	265			
T755	*1	6-M24	200	903	16-M16	305	265
	*3	Note: 3-M18	190	363			
	*2	6-M18	130	363			

- Bolt: Hexagon socket head bolts of strength class 10.9 of JIS B 1176.
- Seat scratching measures: Spring washer (JIS B 1251, 2 types)
- Locking measure: Adhesive (Loctite 262, etc) in addition to conical spring washers
- Recommended liquid gasket: ThreeBond Co., Ltd., Liquid gasket ThreeBond 1215

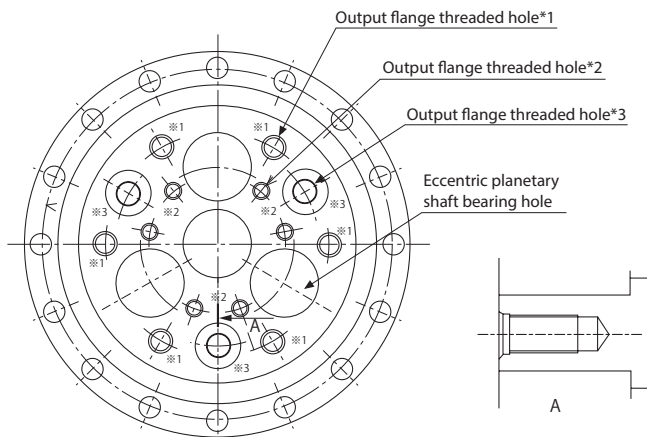

Fig. 6-15 Output flange threaded holes

Note : For the output flange, be sure to tighten the mounting bolts *3 to the tightening torque indicated in Table 6-7. If the bolts are not tight, the reducer may become disassembled.

[6] Coupling with Other Machines

■ UA Series (assembly example 1)

[1]

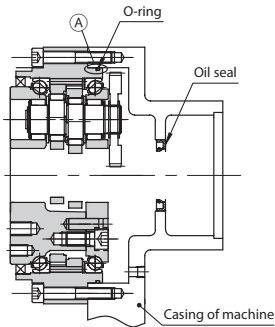

- Insert the O-ring into the frame and fasten the CYCLO reducer to the machine casing with bolts. (Spigot A)
(Use a seal structure between the input shaft gear and the machine casing.) In this assembly example, the casing of machine and motor adapter are shared.)

[2]

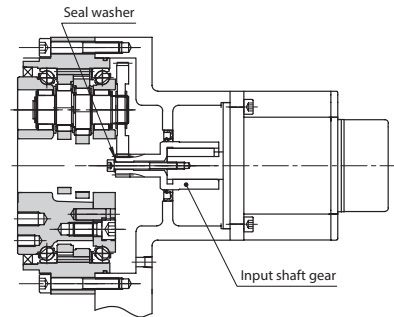

- Apply an anti-fretting agent to the motor shaft.
- Fasten the input shaft gear to the motor shaft a key and bolts
Put a seal washer on the bolt.)
- Align the phase of the input shaft gear and eccentric shaft gear, and fasten the motor to the CYCLO reducer with bolts.

[3]

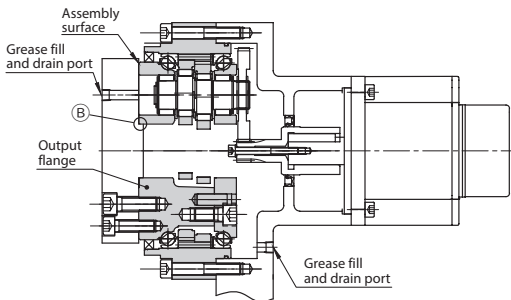

- Apply liquid gasket to the assembly surface and attach the output flange to the output shaft of the machine with bolts. (Spigot B)
- Fill the grease from the machine casing grease fill/drain port (refer to P13), and close each grease fill/drain port.

Fig. 6-16 Assembly procedure UA series (assembly example 1)

[6] Coupling with Other Machines

■ UA Series (assembly example 2)

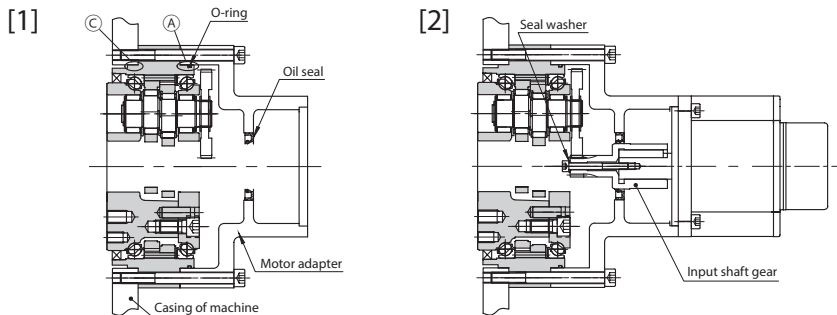

- Insert the O-ring into the frame, and tightly fasten the motor adapter plate and CYCLO reducer to the machine casing with bolts. (Spigot (A), (C)) (Use a seal structure between the input shaft gear and the machine casing.)

- Apply an anti-fretting agent to the motor shaft.
- Fasten the input shaft gear to the motor shaft a key and bolts (Put a seal washer on the bolt.)
- Align the phase of the input shaft gear and eccentric shaft gear, and fasten the motor to the CYCLO reducer with bolts.

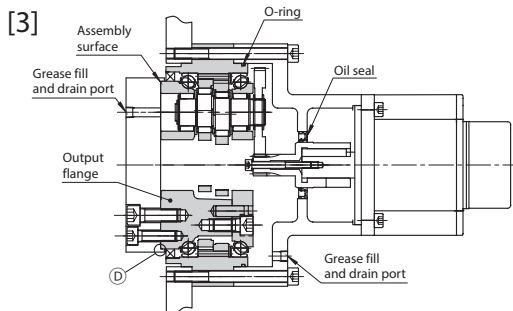

- Apply liquid gasket to the assembly surface and attach the output flange to the output shaft of the machine with bolts. (Spigot (D))
- Fill the grease from the machine casing grease fill/drain port (refer to P13), and close each grease fill/drain port.

Fig. 6-17 Assembly procedure UA series (assembly example 2)

Table 6-8 Mounting bolts UA series (for assembly examples 1 and 2)

Frame size	Tightening of the output flange			Tightening of the reducer part		
	Bolt Number and size	Bolt PCD mm	Bolt tightening torque N·m	Bolt Number and size	Bolt PCD mm	Bolt tightening torque N·m
UA15	15-M6	72	15.7	16-M5	123.5	9.1
	9-M6	48				
UA25	9-M10	86	76.5	12-M8	151	38.3
	6-M10	50				
UA35	15-M10	107	76.5	18-M8	175	38.3
	6-M10	72				
UA45	18-M10	131	76.5 133	18-M10	206	76.5
	9-M12	93				
UA55	15-M12	140	133	20-M10	226	76.5
	9-M12	97				
UA65	21-M12	177	133	18-M12	275	133
	12-M12	136				
UA80	15-M16	193	331	24-M12	305	133
	9-M16	139				

- Bolt: Hexagon socket head bolts of strength class 12.9 of JIS B 1176.
- Seat scratching measures: Spring washer (JIS B 1251, 2 types)
- Locking measure: adhesive (Loctite 262, etc) in addition to conical spring washers
- Recommended liquid gasket: ThreeBond Co., Ltd., Liquid gasket ThreeBond 1215

[7] Operation

DANGER

- Do not touch rotating parts during operation; otherwise, loose clothing caught in these rotating parts may result in serious injury.

CAUTION

- Do not put fingers or foreign object into the opening of the reducer; otherwise, injury or damage to the equipment may result.
- The reducer will become very hot during operation. Do not touch or come in contact with the unit; otherwise, burns may result.
- If anomaly occurs during operation, stop operation immediately; otherwise, injury may result.
- Do not operate the unit in excess of the rating; otherwise, injury or damage to the equipment may result.

7-1 Check Before Operation

After installation, check the following items before starting operation.

- Is the coupling with the driven machine performed correctly?
- Are the mounting bolts for each part securely tightened?
- Is the direction of rotation as planned?

After checking the items described above, perform a no-load break-in operation and gradually apply a load. When doing this, check the items in Table 7-1.

7-2 Check During Operation

Table 7-1 Check items during operation

Is there any abnormal noise or vibration?	<ul style="list-style-type: none">• Is the housing distorted because the installation surface is not flat?• Is there vibration due to insufficient rigidity of installed parts?• Does the center axis of the driven machine match?• Is vibration of the driven machine transmitted to the reducer?
Is the surface temperature abnormally high?	<ul style="list-style-type: none">• Is the ambient temperature at the place of usage high?

When an abnormality is found, stop operation and contact the nearest agent, dealer or sales office.

[8] Daily Inspection and Maintenance

DANGER

- Do not approach or touch any rotating parts during maintenance or inspection of the unit; otherwise, loose clothing caught in these rotating parts may result in injury or death.

CAUTION

- Do not put fingers or foreign object into the opening of the reducer; otherwise, injury or damage to the equipment may result.
- The reducer will become very hot during operation. Do not touch the unit with bare hands; otherwise, burns may result.
- Identify and provide appropriate corrective action in a timely fashion and according to this maintenance manual if any abnormal operating characteristics are observed. Do not operate the unit corrective action has been taken.
- Do not use damaged reducers; otherwise, injury or damage to the equipment may result.
- We can not assume any responsibility for damage or injury as a result of an unauthorized modification by a customer.
- Dispose of the reducer as general industrial waste.

[8] Daily Inspection and Maintenance

8-1 Daily Inspection

To ensure proper and continued optimum operation, use table1 to perform daily inspections. All of the answers should be "No."

Table 8-1 Daily Inspection

Inspection Item	Details of Inspection
Noise	Is there abnormal sound? Is there sudden change in sound?
Vibration	Is vibration abnormally large? Does vibration change suddenly?
Surface temperature	Is the surface temperature abnormally high? Does the surface temperature rise suddenly?
Grease leakage	Is there any grease leakage from mounting surfaces or oil seal part? Is there any rust on the sliding surface of the oil seal?
Mounting bolts	Have any of the mounting bolts become loose?
Lost motion	Has lost motion increased?

- If any abnormality is found during daily inspection, contact the nearest agent, dealer or sales office.

8-2 Maintenance of Main Unit

- Oil seals have a life, and after long-term use there may be a decrease in the seal effect due to natural deterioration and wear. Although the seal life greatly differs depending on the operating conditions and surrounding environment of the reducer, it is recommended that the seal be replaced every 1 to 3 years. If the sliding surface of the oil seal becomes worn or rusted, replace the seal with a new one. The sliding surface is made of a carbon steel, so rusting may occur and advance due to moisture, etc., which may lead to damage of the oil seal, so periodically take rust prevention measures.
- Maintenance such as replacing oil seals and grease, disassembly inspection and repairs should never be attempted by the customer, but should always be performed by a skilled worker of this company who has special tools and expertise. In the case of maintenance with disassembly, please contact the nearest agent, dealer or sales office.

9-1 Structural Drawing (A series)

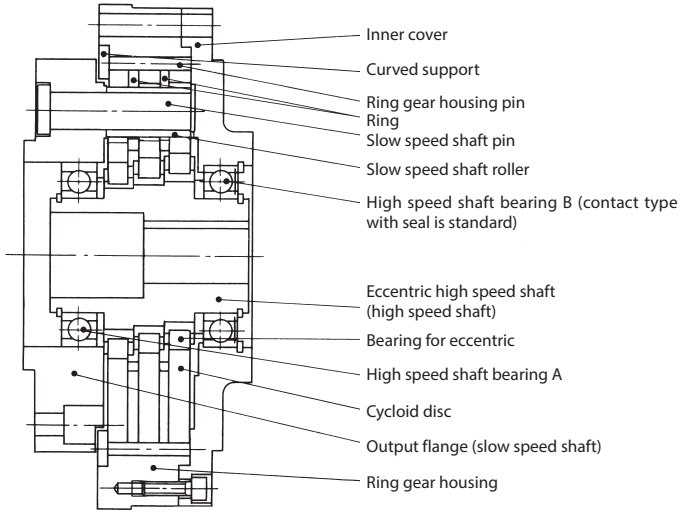

Fig. 9-1 FC Type

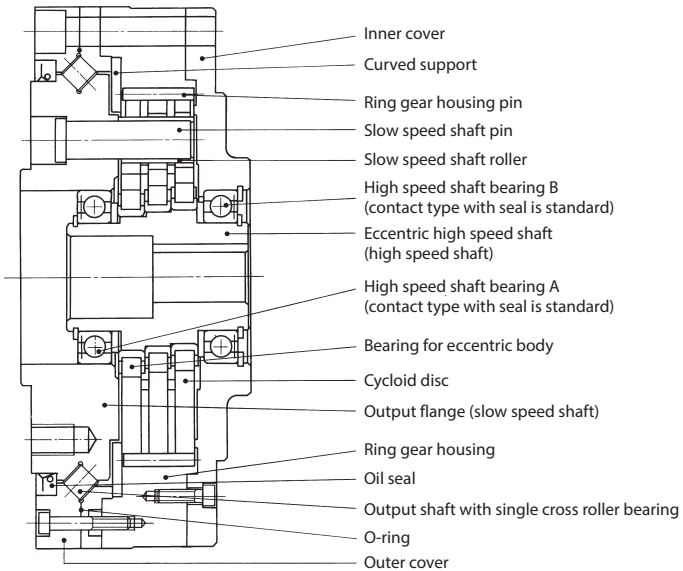

Fig. 9-2 F1C Type

[9] Structural Drawing

9-1 Structural Drawing (A series)

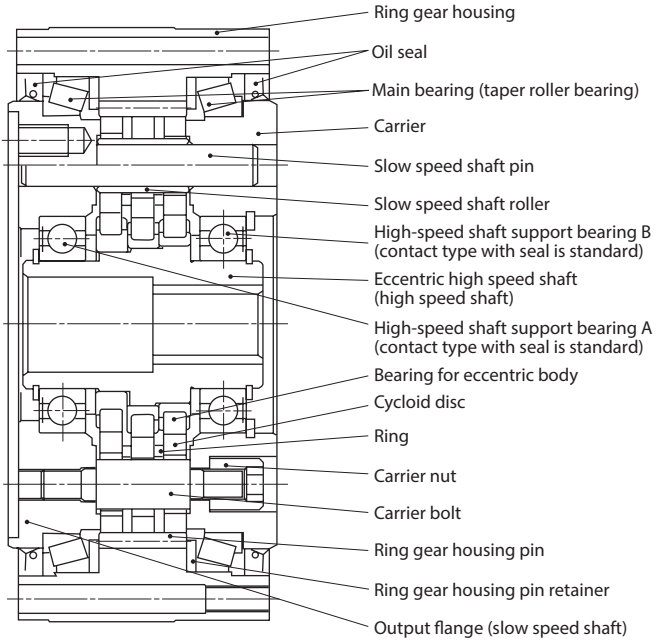

Fig. 9-3 F2C Type

9-2 Structural Drawing (D Series, DA Series)

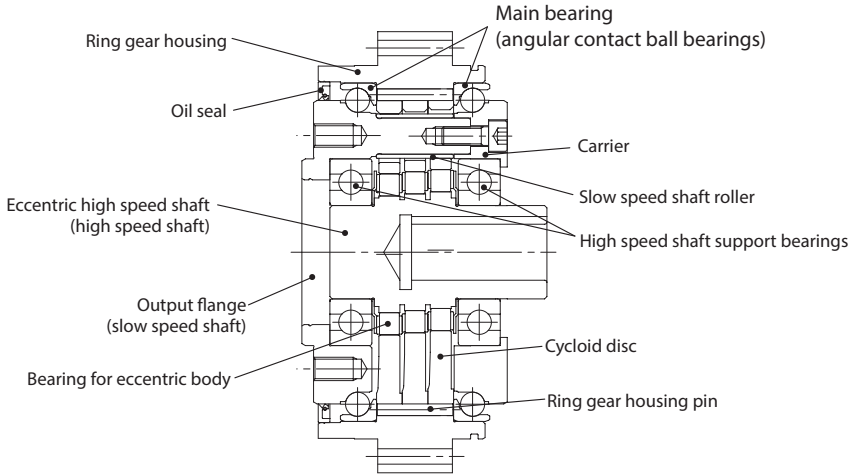

Fig. 9-4 F4C Type

[9] Structural Drawing

9-3 Structural Drawing (C Series)

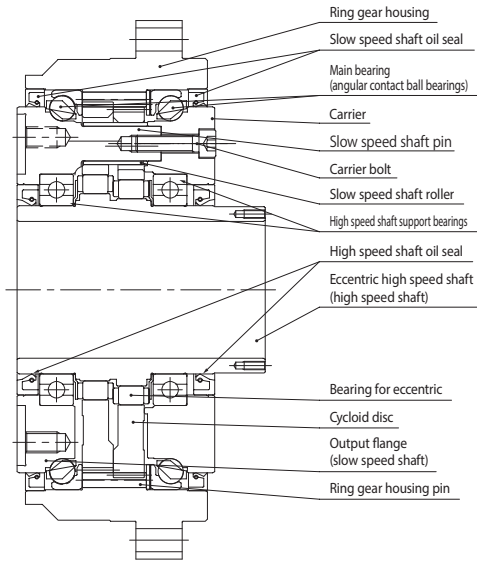

Fig. 9-5 F4C Type

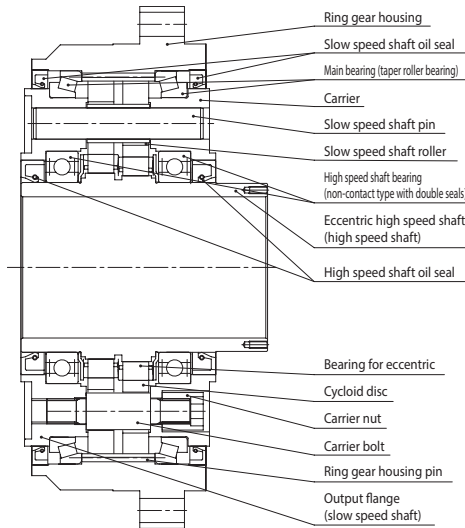

Fig. 9-6 F2C Type

9-3 Structural Drawing (T Series)

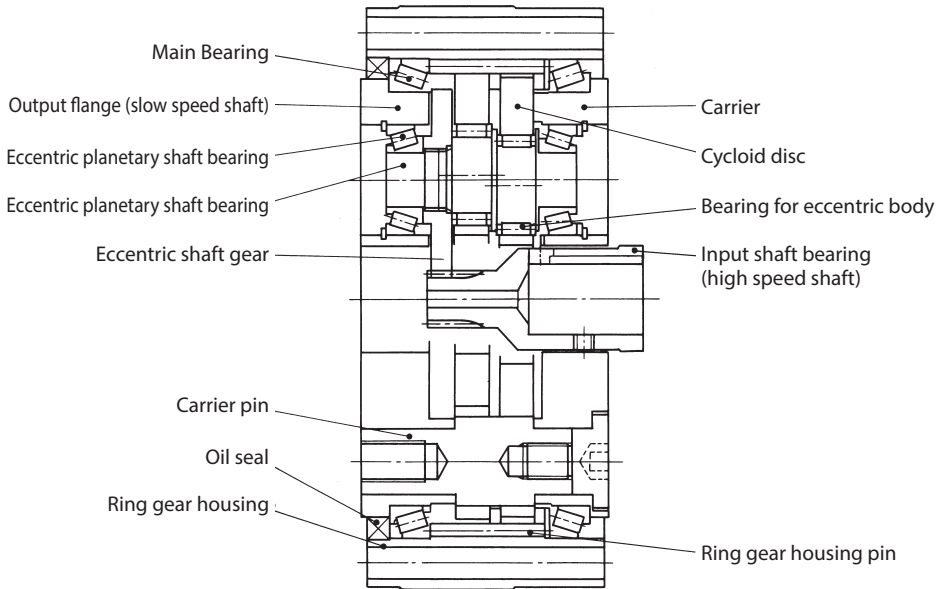

Fig. 9-7 F2C Type

[9] Structural Drawing

9-5 Structural Drawing (UA Series)

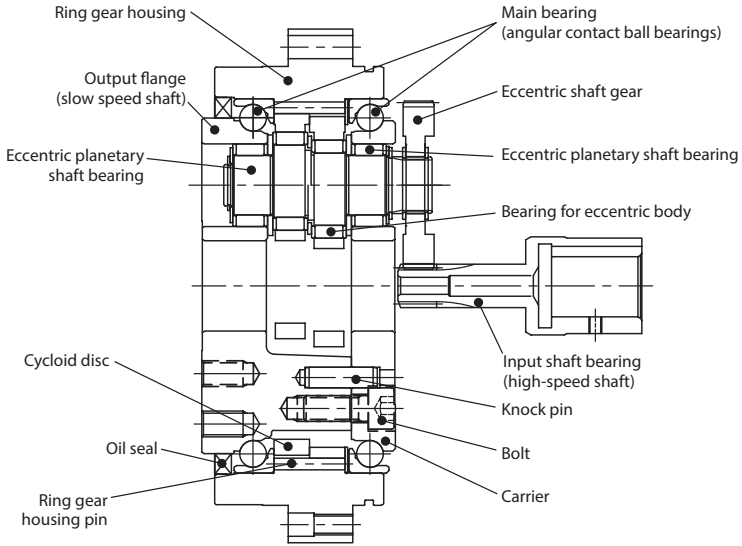

Fig. 9-8 F4C Type

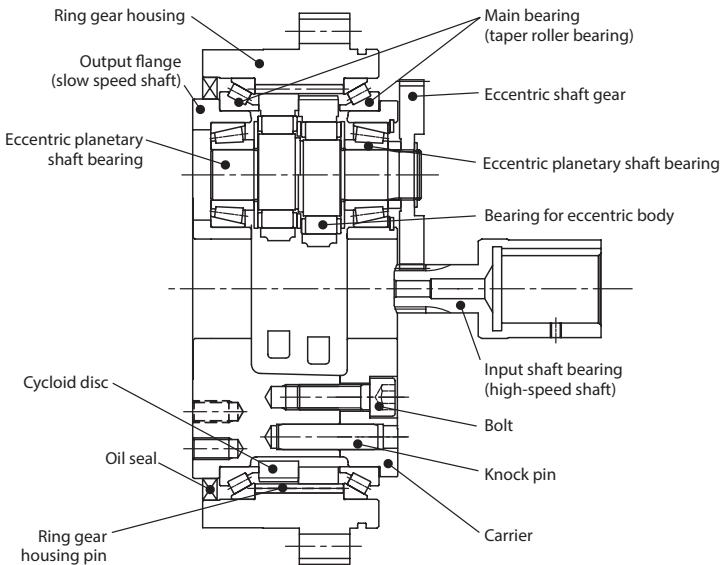

Fig. 9-9 F2C Type

[10] Warranty

The scope of our warranty for our products is limited to the range of our manufacture.
Warranty (period and contents)

Warranty Period	The warranty period for the Products shall be earlier, 18 months after the shipment of the Products from the seller's works factory, or 12 months after starting operation, whichever is first.
Description	If the product failed within the warranty period, during which despite a proper mounting, connection and maintenance & administration are followed according to the maintenance manual, and the product is properly run based on the specification on the catalog or under conditions agreed separately, we will repair or provide an alternative product at our discretion for free of charge, except the exclusions below. However, as far as the product is connected with customers' other devices, we will not indemnify those expenses on dismounting from/mounting on the devices, etc. and other associated construction expenses, transportation expenses and opportunity loss and operation loss the customers suffered from, and other indirect damages.
Exclusion from the Warranty	The following items will be excluded from the warranty: <ol style="list-style-type: none">1. A breakdown resulting from defects in the mounting of the product and connection with other devices, etc.2. A breakdown resulting from insufficient maintenance & administration and improper handling of the product, including a case that the product is not stored according to our defined storage manual.3. A breakdown resulting from operation which does not fall within our specification and other operation conditions and use status we hardly can know or a failure caused by the use of lubricant which we do not recommended.4. A breakdown resulting from defects in or special specification of devices, etc. connected by customers.5. A breakdown resulting from disassembly, parts replacement, and modification conducted by the customer.6. A breakdown resulting from defects in parts supplied or specified by customers.7. A breakdown caused by inevitable force including earthquake, fire, flood disaster, salt damage, gas damage, and lightning strike, etc.8. Natural wear and tear, abrasion, and deterioration of such relevant consumable parts as a bearing and oil seal, etc. under normal usage.9. A breakdown caused for reasons not attributable to each of the above item.

Worldwide Locations

U.S.A.

Sumitomo Machinery Corporation of America (SMA)
4200 Holland Blvd. Chesapeake, VA 23323, U.S.A.
TEL (1)757-485-3355 FAX (1)757-485-7490

Canada

SM Cyclo of Canada, Ltd. (SMC)
1453 Cornwall Road, Oakville, ON L6J 7T5, Canada
TEL (1)905-469-1050 FAX (1)905-469-1055

Mexico

SM Cyclo de México, S.A. de C.V. (SMME)
Fresnos #201, Pocket Park Oriente, 67258 Azteca, N.L.
México
TEL (52)81-8144-5130 FAX (52)81-8144-5130

Brazil

Sumitomo Indústrias Pesadas do Brasil Ltda. (SHIB)
Av. Sumitomo, 500 – Itaim Mirim – Itu/SP – CEP:
13312-839 – Brazil
TEL (55)11-4403-9292

Chile

SM-Cyclo de Chile Ltda. (SMCH)
Camino a Coronel Km.10 Modulo 3A, San Pedro de
la Paz, Biobío, Chile
TEL (56)41-246-9806 FAX (56)41-246-9808

Argentina

SM-Cyclo de Argentina S.A. (SMAR)
Ing Delpini 2230, B1615KGB Malvinas Argentinas,
Grand Bourg, Buenos Aires, Argentina
TEL (54)3327-45-4095

Guatemala

SM Cyclo de Guatemala Ensambadora, Ltda. (SMGT)
Parque Industrial Unisur, 0 Calle B 19-50 Zona 3,
Bodega D-1 Delta Bárcenas, Villa Nueva, Guatemala
TEL (502)6648-0500 FAX (502)6631-9171

Colombia

SM Cyclo Colombia, S.A.S. (SMCO)
Parque Industrial Celta, Km 7.0 Autopista Medellín,
Costado Occidental, Funza, CUN, 250027, Colombia
TEL (57)1-300-0673 FAX (57)1300-0673 ext. 105

Peru

SM Cyclo de Perú, S.A.C. (SMPE)
Jr. Monte Rosa 255, Oficina 702, Santiago de Surco-
Lima 15038, Peru
TEL (51)1-7130342 FAX (51)1-7150223

Germany

Sumitomo (SHI) Cyclo Drive Germany GmbH (SCG)
Cyclostraße 92, 85229 Markt Indersdorf, Germany
TEL (49)8136-66-0

Austria

Sumitomo (SHI) Cyclo Drive Germany GmbH (SCG)
Austria Branch Office
Gruentalerstraße 30A, 4020 Linz, Austria
TEL (43)664-2840490

Belgium

Hansen Industrial Transmissions NV (HIT)
Leonardo da Vincilaan 1, Edegem, Belgium
TEL (32)3-450-12-11

France

SM-Cyclo France SAS (SMFR)
8 Avenue Christian Doppler, 77700 Serris, France
TEL (33)1-64-17-17-20

Italy

SM-Cyclo Italy Srl (SMIT)
Via dell' Artigianato 23, 20007 Cornaredo MI, Italy
TEL (39)293-481101

Spain

Sociedad Industrial de Transmisiones, S.A. (SIT)
Paseo de Ubarburu 67, 20014 San Sebastián
Guipúzcoa, Spain
TEL (34)9434-572-00

United Kingdom

SM-Cyclo UK Ltd. (SMUK)
29 Bergen Way, Hull, HU7 0YQ, United Kingdom
TEL (44)1482-790340

Turkey

SM-Cyclo Turkey Güç Aktarım Sis. Tic. Ltd. Sti. (SMTR)
Barbaros Mh. Çiğdem Sk. Ağaoğlu, Office Mrk. No:1 Kat:
D.18, 34746, Ataşehir/İstanbul, Turkey
TEL (90)216-250-60-69 FAX (90)216-250-55-56

India

Sumi-Cyclo Drive India Private Limited (SDI)
Gat No. 186, Global Raisonni Industrial Park
Alandi Markal Road, Fulgaon, Pune 411 033, India
TEL (91)96077-45353

China

Sumitomo (SHI) Cyclo Drive Shanghai, Ltd. (SCS)
Room 1101, SMEG Plaza, Office Building, No.1386
Hongqiao Road, Changning District, Shanghai, China
200336
TEL (86)21-3462-7877 FAX (86)21-3462-7922

Hong Kong

SM-Cyclo of Hong Kong Co., Ltd. (SMHK)
Unit 19, 28/F, Metropole Square, 2 On Yiu Street,
Sha Tin, New Territories, Hong Kong, China
TEL (852)2460-1881 FAX (852)2460-1882

Taiwan

Tatung SM-Cyclo Co., Ltd. (TSC)
22, Chungshan N. Rd., 3rd Sec. Taipei, Taiwan, 104, R.O.C.
TEL (886)2-2595-7275 FAX (886)2-2595-5594

Korea

Sumitomo (SHI) Cyclo Drive Korea, Ltd. (SCK)
913, 19 Saemunan-ro 5-gil, Jongno-gu, Seoul,
Republic of Korea 03173
TEL (82)2-730-0151 FAX (82)2-730-0156

Singapore

Sumitomo (SHI) Cyclo Drive Asia Pacific Pte. Ltd. (SCA)
15 Kwong Min Road, Singapore 628718, Singapore
TEL (65)6591-7800 FAX (65)6863-4238

Philippines

Sumitomo (SHI) Cyclo Drive Asia Pacific Pte. Ltd. Philippines Branch Office (SMPPH)
C4 & C5 Buildings Granville Industrial Complex,
Governor's Drive, Bo. Bancal, Carmona, 4116 Cavite,
Philippines
TEL (63)2-8584-4921 FAX (63)2-8584-4922

Vietnam

SM-Cyclo (Vietnam) Co., Ltd. (SMVN)
Factory 2B, Lot K1-2-5, Road No. 2-3-5A,
Le Minh Xuan Industrial Park, Binh Chanh Dist.,
Ho Chi Minh, Ho Chi Minh City, Vietnam
TEL (84)28-3766-3709 FAX (84)28-3766-3710

Malaysia

SM-Cyclo (Malaysia) Sdn. Bhd. (SMMA)
No.7C, Jalan Anggerik Mokara 31/56, Kota Kemuning,
Seksyen 31, 40460 Shah Alam, Selangor, Malaysia
TEL (60)3-5121-0455 FAX (60)3-5121-0578

Indonesia

PT. SM-Cyclo Indonesia (SMID)
Cikarang Jalan Sungkai Blok F 25 No. 09K, Delta Silicon III,
Lippo Cikarang, Bekasi, Jawa Barat, Indonesia
TEL (62)21-29612100 FAX (62)21-29612111

Thailand

SM-Cyclo (Thailand) Co., Ltd. (SMTH)
1 Empire Tower, 21st Floor Unit 2103-4, South Sathorn
Road, Yan Nawa, Bangkok 10120, Thailand
TEL (66)2-670-0998 FAX (66)2-670-0999

Australia

Sumitomo (SHI) Hansen Australia Pty. Ltd. (SHAU)
181 Power Street Glendenning, NSW 2761, Australia
TEL (61)1300-037-483

Japan

Sumitomo Heavy Industries, Ltd. (SHI)
ThinkPark Tower, 1-1 Osaki 2-chome, Shinagawa-ku,
Tokyo 141-6025, Japan
TEL (81)3-6737-2511 FAX (81)3-6866-5160

Specifications, dimensions, and other items are subject to change without prior notice.