

Inverter HF-620 Series

Thank you for purchasing HF-620 series Inverter. This is a manual that explains the handling, maintenance, etc. of the HF-620. This Manual contains only the minimum information for handling. Please be sure to read this Manual, as well as the HF-620 User's Guide for extended mode, which contains detailed instructions, to use it correctly. Please obtain the User's Guide for HF-620 from our website or agency.

© Sumitomo Heavy Industries, Ltd. All rights reserved

Name of Parts

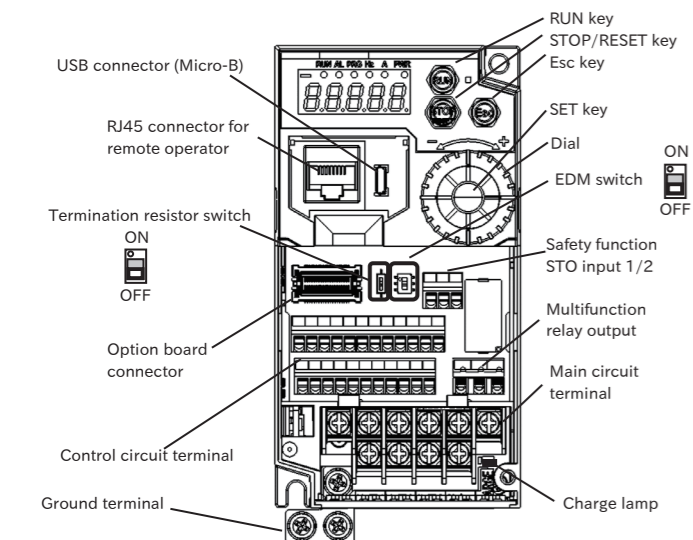

Dimensions and Connection Diagram

Dimensions

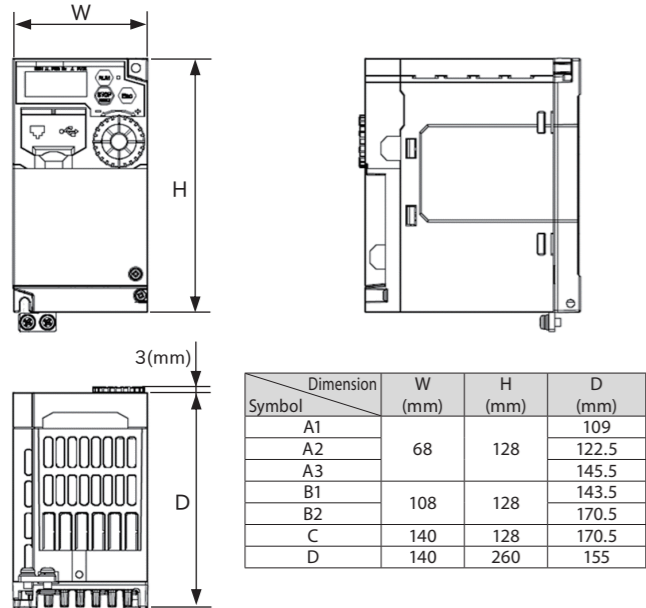

Capacity (kW)	0.2	0.4	0.75	1.5	2.2	3.7	5.5	7.5
Power Supply								
Single phase 200V	A1	A2	B2	B2	B2	-	-	-
Three phase 200V	A1	A2	A3	B2	B2	C	D	D
Three phase 400V	-	B1	B2	B2	B2	C	D	D

Capacity (kW)	0.2	0.4	0.75	1.5	2.2	3.7	5.5	7.5
Power Supply								
Single phase 200V	1.0	1.1	1.6	1.8	1.8	-	-	-
Three phase 200V	1.0	1.1	1.2	1.6	1.8	2.0	3.5	3.5
Three phase 400V	-	1.5	1.8	1.8	1.8	2.0	3.5	3.5

Standard Connection Diagram

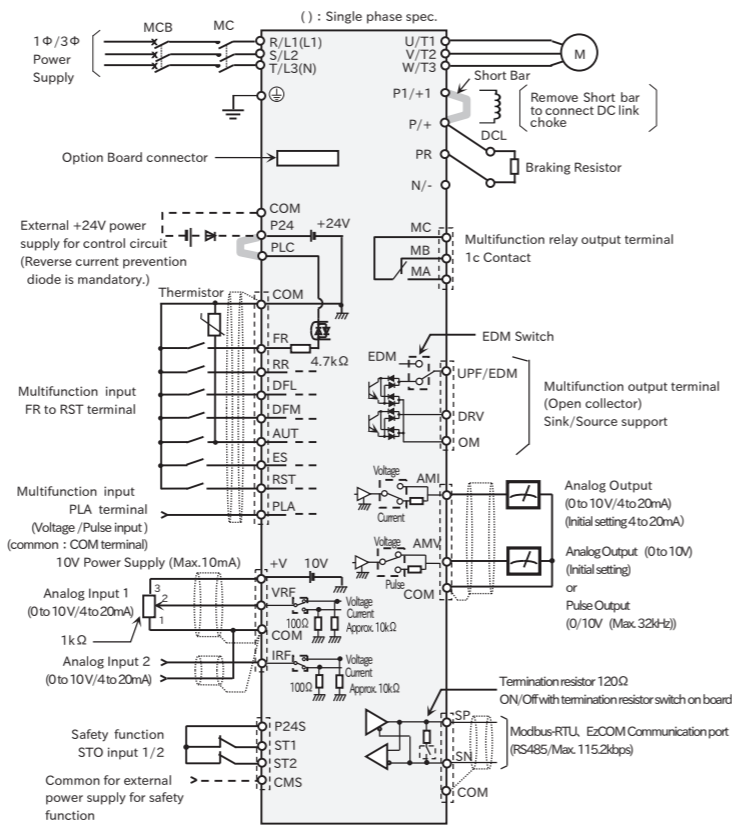

Key and Dial

Name	Function code display	Data display
Esc key	Moves to the next function code group.	Cancels and returns to the function code display.
SET key	Moves to the data display.	Fixes and saves the data and back to the function code display.
Dial	Increases or decreases the function code and data value.	

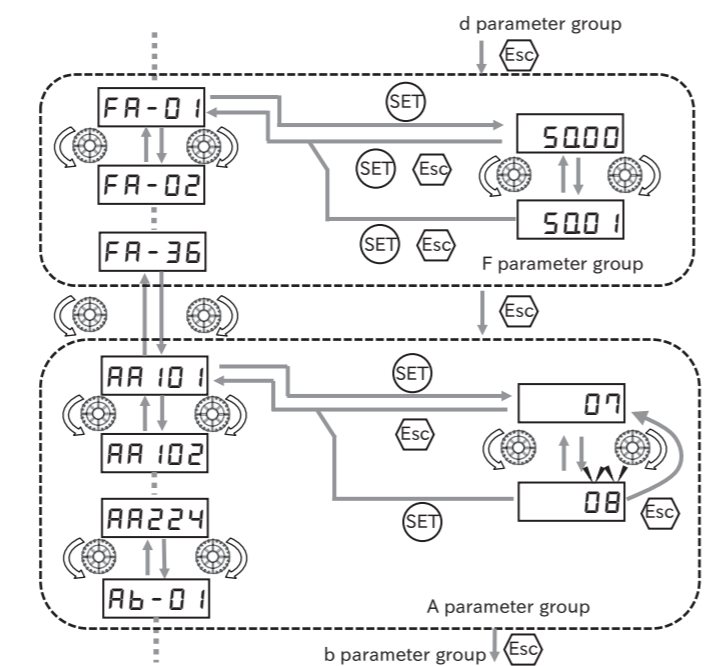

Name	Action
RUN key	RUN from keypad
STOP/RESET key	(in RUN mode) Decelerate and stop the inverter. (in TRIP mode) Reset from a tripped alarm of inverter.

Quick Start Essential Parameters

Parameters mentioned in the quick start

FA-01	Main speed reference setting (monitor)
FA-10	Acceleration time setting (monitor)
FA-12	Deceleration time setting (monitor)
AA101	Main speed input source selection, 1st-motor
AA111	RUN command input source selection, 1st-motor
AA115	STOP mode selection, 1st-motor
bC110	Electronic thermal level setting, 1st-motor
Hb102	Async. Motor capacity setting, 1st-motor
Hb103	Async. Motor number of poles setting, 1st-motor
Hb104	Async. Motor base frequency setting, 1st-motor
Hb105	Async. Motor maximum frequency setting, 1st-motor
Hb106	Async. Motor rated voltage, 1st-motor
Hb108	Async. Motor rated current, 1st-motor

(Tips)

Press and hold SET key to be in the mode to edit digits by digits.

Press Esc to increment and SET to decrement to select digit and then Dial to set that digit.

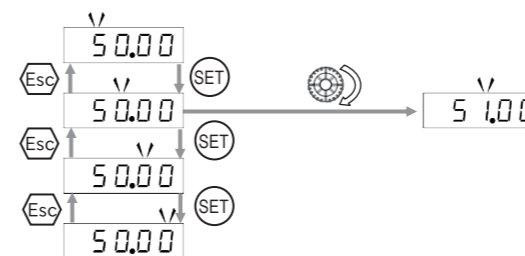

For numbers with 6 digits or more, Esc key and SET key can switch the digits to be displayed.

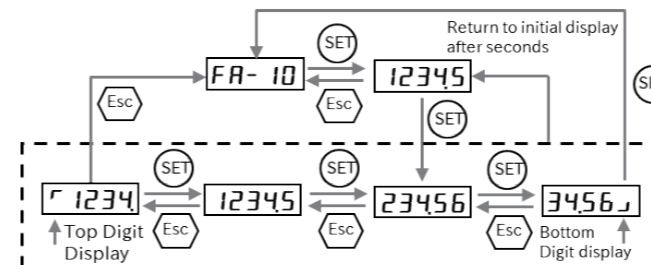

To Set the Frequency Source

- 1) Select "AA101" with Esc key and Dial.
- 2) Press SET key.
- 3) Turn Dial to select "speed input source".

01	Terminal [VRF]
02	Terminal [IRF]
07	Parameter setting
09	Option
12	Pulse input
15	PID function

- 4) Press SET key.

To Set the Output Frequency Using Dial

- When Parameter setting (07) is set on [AA101], set frequency as below.

- 1) Select "FA-01" with Esc key and Dial.
- 2) Press SET key.
- 3) Turn Dial to set output frequency.

0.00 to "Maximum frequency" (Hz)

- 4) Press SET key.

To Set the Run Command Source

- 1) Select "AA111" with Esc key and Dial.
- 2) Press SET key.
- 3) Turn Dial to select "Run Command Source".

00	[FR]/[RR] terminal
01	3-wire
02	Keypad's RUN-key
03	RS485
04	Option

- 4) Press SET key

To Set the Acceleration and Deceleration time

- 1) Select "FA-10" with Esc key and Dial.
- 2) Press SET key.
- 3) Turn Dial to set acceleration time.

0.00 to 3600.00 [s]

- 4) Press SET key.

- 5) Repeat the above to set following the parameter listed below.

FA-12 Deceleration time setting (monitor)

To Set the Stop Mode

- 1) Select "AA115" with Esc key and Dial.
- 2) Press SET key.
- 3) Turn Dial to set stop mode.

00	Deceleration stop
01	Free-run stop

- 4) Press SET key.

To Set the Upper Frequency Limit

- 1) Select "bA101" with Esc key and Dial.
- 2) Press SET key.
- 3) Turn Dial to select 07 (Parameter setting).
- 4) Press SET key.
- 5) Select "bA102" with Esc key and Dial.
- 6) Press SET key.
- 7) Turn Dial to set upper frequency limit.

0.00 to "Maximum frequency" (Hz)

- 8) Press SET key.

To Set the Lower Frequency Limit

- 1) Select "bA103" with Esc key and Dial.
- 2) Press SET key.
- 3) Turn Dial to lower frequency limit.

0.00 to "Maximum frequency" (Hz)

- 4) Press SET key.

To Set the Electronic thermal level

- 1) Select "bC110" with Esc key and Dial.
- 2) Press SET key.
- 3) Turn Dial to set electric thermal level.

(0.00 to 3.00) × Rated current [A]

- 4) Press SET key.

Safety Precautions

■ Indications and meanings of safety information

Be sure to read this manual and all other guides before installation, wiring, operation, maintenance and inspection.

■ Display meaning

DANGER	Indicates that incorrect handling may cause hazardous situations, which have a high chance of resulting in serious personal injury or death and may result in major physical loss or damage.
WARNING	Indicates that incorrect handling may cause hazardous situations, which may result in serious personal injury or death, and may result in major physical loss or damage.
CAUTION	Indicates that incorrect handling may cause hazardous situations, which may result in moderate or slight personal injury or damage and may result in only physical loss or damage.

■ Description of Safety Symbols

	Indicates a danger, warning or caution notice for fire, electric shock and high temperature in the operation of the product. Details are indicated in or near Δ by pictures or words.
Δ	The drawing on the left indicates "a non-specific and general danger or caution".
	The drawing on the left indicates "a possible damage due to electric shock".
	Indicates "what you must not do" to prohibit the described acts in the operation of the product.
	Indicates "what you must do" according to the instructions in the operation of the product.

■ Caution!

DANGER	Incorrect handling may result in personal death or severe injury, or may result in damage to the inverter, motor or the whole system.
	Be sure to read the Guide and appended documents thoroughly before installing, wiring, operating, maintaining, inspecting or using the inverter.
	Be sure to read the corresponding explanation thoroughly before installing, wiring, operating, maintaining, inspecting or using the inverter.
	Many of the drawings in the Guide show the inverter with covers and/or parts blocking your view removed to illustrate the details of the product.
	Do not operate the inverter in the status shown in those drawings. If you have removed the covers and/or parts, be sure to reinstall them in their original positions before starting operation and follow all the instructions in this guide when operating the inverter.

■ Precautions for installation

WARNING	Risk of Fire!
	<ul style="list-style-type: none"> Do not place flammable materials near the installed inverter. Prevent foreign matter (e.g., cut pieces of wire, sputtering welding materials, iron chips, wire, and dust) from entering the inverter.
	<ul style="list-style-type: none"> Install the inverter on a non-flammable surface, e.g., metal. Install the inverter in a well-ventilated indoor site not exposed to direct sunlight. Avoid places where the inverter is exposed to high temperature, high humidity, condensation, dust, explosive gases, corrosive gases, flammable gases, gridding fluid mist, hydrogen sulfide or salt water.
Risk of Injury!	
	Do not install or operate the inverter if it is damaged or parts are missing.
Risk of injury due to the inverter falling!	
	When carrying the inverter, do not hold its parts to cover terminals or connectors.
	<ul style="list-style-type: none"> Install the inverter on a structure able to bear the weight specified in the User's Guide. Install the inverter on a vertical wall that is free of vibrations.
Risk of failure of the inverter!	
	<ul style="list-style-type: none"> The inverter is precision equipment. Do not allow it to fall or be subject to high impacts. Also do not step on it or place a heavy load on it. Avoid places where static electricity discharges often occur (for example, on a rug) for the operation of the product.
	In order to discharge static electricity from your body, touch a safe metal surface first before starting the operation.

■ Precautions for Wiring

DANGER	Risk of an electric shock and/or fire!
	<ul style="list-style-type: none"> Be sure to ground the inverter. Entrust wiring work to a qualified electrician. Before the wiring work be sure to turn off the power supply and wait for more than 10 minutes. (Confirm that the voltage between terminals [P+] and [N-] is 45Vdc or less.)
Risk of failure of the inverter!	
	Do not pull the wire after wiring.
Risk of an electric shock and/or injury!	
	Perform the wiring only after installing the inverter.
WARNING	
Risk of injury or fire!	
	Do not connect AC power supply to any of the output terminals ([U T1], [V T2], and [W T3]).
	Make sure that the voltage and frequency of AC power supply match the rated voltage (AC input voltage) and frequency of your inverter.
Risk of electric shock and injury!	
	<ul style="list-style-type: none"> Before operating the slide switch in the inverter, be sure to turn off the power supply. Since the inverter supports two modes of cooling-fan operation, the inverter power is not always off, even when the cooling fan is stopped. Before operating the switch, be sure to turn off the power supply and wait for more than 10 minutes. (Confirm that the DC voltage between terminals [P+] and [N-] is 45Vdc or less.) Prevent the distribution cable from being compressed or getting caught to avoid damage to the cable.
Risk of fire!	
	<ul style="list-style-type: none"> Do not use a single-phase input for 3 phase models. Do not connect a resistor directly to between [P1+] and [N-] or [P+] and [N-]. Do not use the magnetic contactor installed on the primary and secondary sides of the inverter to stop its operation.
	<ul style="list-style-type: none"> Tighten the screws and bolts with the specified torque. No screws or bolts must be left loose. Connect an earth-leakage breaker to the power input circuit. Use only the power cables, earth-leakage breaker, and magnetic contactors that have the specified capacity (ratings).
Risk of damage to the inverter and burnout of the motor!	
	Do not operate the inverter when an output phase is lost (output phase loss).

■ Precautions for Running and Test Running

DANGER	Risk of electric shock or fire!
	<ul style="list-style-type: none"> While power is supplied to the inverter, do not touch any internal part or the terminal of the inverter. Also do not check signals or connect or disconnect any wire or connector. While power is supplied to the inverter, do not touch any internal part of the inverter. Also do not insert a bar in it.
Risk of electric shock!	
	<ul style="list-style-type: none"> Be sure to close the terminal block cover before turning on the inverter power. Do not open the terminal block cover while power is being supplied to the inverter or voltage remains inside. Do not touch the internal PCB, terminal block or connector while power is being supplied to the inverter or voltage remains inside. Do not operate switches in the inverter or on the board with wet hands.
Risk of injury or fire!	
	While power is supplied to the inverter, do not touch the terminal of the inverter, even if it has stopped.
Risk of injury and damage to machine!	
	Do not select the retry mode for controlling an elevating or traveling device because free-running status occurs in retry mode.
Risk of injury!	
	If the retry mode has been selected, the inverter will restart suddenly after a break upon detection of an error. Stay away from the machine controlled by the inverter when the inverter is under such circumstances. (Design the machine so that human safety can be ensured, even when the inverter restarts suddenly.)
	<ul style="list-style-type: none"> The STOP/RESET key on the operator keypad can be enabled/disabled using the "STOP-key enable [AA-13]" and it is effective only when there is no connection abnormality between the keypad and the main unit. Prepare an emergency stop switch separately. If an operation command has been input to the inverter before a short-term power failure, the inverter may restart operation after the power recovery. If such a restart may put persons in danger, design a system configuration that disables the inverter from restarting after power recovery. If an operation command has been input to the inverter before the inverter enters alarm status, the inverter will restart suddenly when the alarm status is reset (by terminal, key operation or communication). Before resetting the alarm status, make sure that no operation command has been input. When an unexpected event occurs, do not touch the inverter or cable. Make sure to understand and check the functions the inverter provides to ensure safety. Be careful that operation commands or resetting operation do not cause an unexpected restart. When an error (alarm) occurs, before moving to the next operation (resetting the alarm status or reapplying the power), make sure that no operation command has been input. If the inverter has received an operation command, it will restart automatically.
WARNING	
Risk of injury and damage to machine!	
	The inverter allows you to easily control the speed of the motor or machine operations. Before operating the inverter, confirm the capacity and ratings of the motor or machine controlled by the inverter.
Risk of burn injury!	
	Do not touch the heat sink, which heats up during the inverter operation.
Risk of injury!	
	Install an external brake system if needed.

■ Precautions for Maintenance/Daily Inspection

DANGER	Risk of electric shock!
	Entrust only a designated person for maintenance, inspection, and the replacement of parts. (Be sure to remove wristwatches and metal accessories, e.g., bracelets, before maintenance and inspection work and to use insulated tools for the work.)
	Before inspecting the inverter, be sure to turn off the power supply and more than 10 minutes. (Confirm that the Charge lamp on the inverter is off and the DC voltage between terminals [P+] and [N-] is 45 VDC or less.)

■ Precautions for Disposal

DANGER	Risk of injury and explosion!
	For disposal of the inverter, outsource to a qualified industrial waste disposal contractor. Disposing of the inverter on your own may result in an explosion of the capacitor or produce poisonous gas.
	A qualified industrial waste disposal contractor includes industrial waste collector/transporter and industrial waste disposal operator. Follow the laws and regulations of each country for disposing of the inverter.

■ Other Cautions

DANGER	Risk of electric shock, fire and injury!
	Never modify the inverter.
CAUTION	Risk of significantly shortening the life cycle of the product!
	If wood materials for packaging need to be sterilized and disinfected, be sure to use a means other than the wood fumigation method. If the product is included in the fumigation treatment, electronic parts could receive critical damage from the emitted gases or vapors. Especially, halogen disinfectants (including fluorine, chlorine, bromine and iodine) can cause corrosion in the capacitor.

■ Information Security

In the control system, recently, the connection and cooperation with the information communication system have progressed and security risks including cyber-attacks are growing. A system applying this product needs to take physical security measures mainly in the installation location and security measures for use via information network are needed.

- [Security risk example via the information network]
 - Abnormal operation, performance degradation, information leakage and data tampering by attacks from outside
 - Communication error and malfunction by overloading a communication network
 - Malfunction, harm and damage occurrence due to programs and/or data tampering from outside
- The customer needs to take security measures, because the required security level in the control system is different depending on system. In addition, continuous improvement measures will be required to maintain the security level, because the assumed security risk is not fixed and it will be changing on a daily basis. In a system using this product, whether or not applying security protection support functions, Hitachi Industrial Equipment Systems will not be able to bear responsibility for any trouble, accident or damage caused by unauthorized external access. The customer needs to clarify the target of the security protection in the system and take measures including the following examples for the construction and operation of the system.
 - Take measures in the operational management, such as to lock the location of devices or grant access only to limited persons.
 - Update antivirus of network device to connect to the control system.
 - Utilize the security functions of the device configuring the network.
 - Monitor the system and make a self-assessment for security periodically.

Compliance to UL standards

This section summarizes the items required for UL standard compliant inverter installation. (The English text is the original and the Japanese text is for reference purposes.)

GENERAL:
HF-620 series inverter is open type AC Inverter with three/single phase input and three phase output. It is intended to be used in an enclosure. It is used to provide both an adjustable voltage and adjustable frequency to the AC motor. The inverter automatically maintains the required volts-Hz ratio allowing the capability through the motor speed range. It is multi-rated device, and the ratings are selectable according to load types by operator with keypad operation.

Markings:
Maximum Surrounding Temperature:
• ND (Normal Duty): 50 deg C
• LD (Low Duty) : 40 deg C
Storage Environment rating:
• -20 to 65 deg C (for transportation)
Instruction for installation:
• Pollution degree 2 environment and Overvoltage category 3
Electrical Connections:
• See section [5.2 Main Circuit Terminal] of user's guide.
Interconnection and wiring diagrams:
• See section [5.4 Control Circuit Terminal] of user's guide.
Short circuit rating and overcurrent protection device rating:
• Single phase 200V class series, HF620S-A20 to HF620S-2A2 models.
- [Non-semiconductor Fuses]
Suitable for use on a circuit capable of delivering not more than 5,000 rms symmetrical amperes, 240 V maximum.
- [Semiconductor Fuses]
Suitable for use on a circuit capable of delivering not more than 100,000 rms symmetrical amperes, 240 V maximum.
• Three phase 200V class series, HF6202-A20 to HF6202-3A7 models.
- [Non-semiconductor Fuses]
Suitable for use on a circuit capable of delivering not more than 5,000 rms symmetrical amperes, 240 V maximum.
• Three phase 200V class series, HF6202-5A5 and HF6202-7A5 models.
- [Non-semiconductor Fuses]
Suitable for use on a circuit capable of delivering not more than 5,000 rms symmetrical amperes, 240 V maximum.
• Three phase 200V class series, HF6202-A20 to HF6202-7A5 models.
- [Semiconductor Fuses]
Suitable for use on a circuit capable of delivering not more than 100,000 rms symmetrical amperes, 240 V maximum.
• Three phase 400V class series, HF6204-A40 to HF6204-7A5 models.
- [Non-semiconductor Fuses]
Suitable for use on a circuit capable of delivering not more than 5,000 rms symmetrical amperes, 480 V maximum.
• Three phase 400V class series, HF6204-A40 to HF6204-7A5 models.
- [Semiconductor Fuses]
Suitable for use on a circuit capable of delivering not more than 100,000 rms symmetrical amperes, 480 V maximum.
• Integral solid state short circuit protection does not provide branch circuit protection. Branch circuit protection must be provided in accordance with the National Electrical Code and any additional local codes.
Integral:
• Integral solid state short circuit protection does not provide branch circuit protection. Branch circuit protection must be provided in accordance with the Canadian Electrical Code, Part 1. (For Canada)

■ Field wiring conductor size and torque values making for wiring terminal

Model	Screw Size	Required torque	Wire Range
HF620S-A20	M3.5	1.0	AWG16 (1.3mm²)
HF620S-A40	M3.5	1.0	AWG16 (1.3mm²)
HF620S-A75	M4	1.4	AWG12 (3.3mm²)
HF620S-1A5	M4	1.4	AWG10 (5.3mm²)
HF620S-2A2	M4	1.4	AWG10 (5.3mm²)
HF6202-A20	M3.5	1.0	AWG16 (1.3mm²)
HF6202-A40	M3.5	1.0	AWG16 (1.3mm²)
HF6202-A75	M3.5	1.0	AWG16 (1.3mm²)
HF6202-1A5	M4	1.4	AWG14 (2.1mm²)
HF6202-2A2	M4	1.4	AWG12 (3.3mm²)
HF6202-3A7	M4	1.4	AWG10 (5.3mm²)
HF6202-5A5	M5	3.0	AWG6 (13mm²)
HF6202-7A5	M5	3.0	AWG6 (13mm²)

Model	Screw Size	Required torque	Wire Range
HF6204-A40	M4	1.4	AWG16 (1.3mm²)
HF6204-A75	M4	1.4	AWG16 (1.3mm²)
HF6204-1A5	M4	1.4	AWG16 (1.3mm²)
HF6204-2A2	M4	1.4	AWG14 (2.1mm²)
HF6204-3A7	M4	1.4	AWG12 (3.3mm²)
HF6204-5A5	M5	3.0	AWG10 (5.3mm²)
HF6204-7A5	M5	3.0	AWG10 (5.3mm²)

Field wiring Terminal marking for wire type:
Use copper conductors only
Temperature rating of field wiring installed conductor:
For models HF620S-A20, HF620S-A40, HF620S-A75, HF620S-1A5, HF6202-A40, HF6202-A75, HF6202-1A5, HF6204-A40, HF6204-A75, HF6204-1A5, HF6204-2A2 and HF6204-3A7 - 60 degree C only.
Except above models - 75 degree C only.

■ Required protection by Fuse

Model No.	Non-Semiconductor Fuse			Semiconductor Fuse
	Type	Maximum Rating		Manufacturer: Cooper Bussmann LLC
		Voltage	Current	
HF620S-A20 HF620S-A40 HF620S-A75 HF620S-1A5 HF620S-2A2 HF6202-A20 HF6202-A40 HF6202-A75 HF6202-1A5 HF6202-2A2 HF6202-3A7 HF6202-5A5 HF6202-7A5 HF6204-A40 HF6204-A75 HF6204-1A5 HF6204-2A2 HF6204-3A7 HF6204-5A5 HF6204-7A5	Class J Class CC Class G Class T	600V	6 A	FWH-15A14F
			10 A	FWH-15A14F
			20 A	FWH-60B
			30 A	FWH-60B
			30 A	FWH-60B
			30 A	FWH-60B
	600 V	6 A	FWH-15A14F	
		10 A	FWH-15A14F	
		15 A	FWH-25A14F	
		15 A	FWH-25A14F	
		20 A	FWH-60B	
		30 A	FWH-60B	
600 V	60 A	FWH-150B		
	60 A	FWH-150B		
	6 A	FWH-15A14F		
	10 A	FWH-25A14F		
	10 A	FWH-25A14F		
	10 A	FWH-25A14F		
30 A	15 A	FWH-25A14F		
	30 A	FWH-60B		
	30 A	FWH-60B		
	30 A	FWH-60B		

Conformance to EU Directives

- It is necessary to use optional EMC filter to comply with EMC directive (EN61800-3: 2018).
- For earthing, selection of cable, and any other conditions for EMC compliance, please refer to the User's Guide.
- This is a class A product in residential areas it may cause radio interference, in which case the user may be required to take adequate measures to reduce interference.

■ Sumitomo Heavy Industries, Ltd.

Address: 6-1 Asahi-cho, Obu-shi, Aichi 474-8501, Japan

■ Sumitomo (SH) Cyclo Drive Germany GmbH

Address: Cyclostraße 92, 85229 Markt Indersdorf, Germany

Functional Safety

For use of this product as a safety device, please refer to safety function guide for extended mode obtained from below address.

Warranty

Warranty period:
The warranty shall be 18 months from date of shipment or 12 months after initial operation, whichever is shorter.

Warranty condition:
In the event that any problem or damage to the Product arises during the "Warranty Period" from defects in the Product whenever the Product is properly installed and combined with the Buyer's equipment or machines maintained as specified in the maintenance manual, and properly operated under the conditions described in the catalog or as otherwise agreed upon in writing between the Seller and Buyer or its customers; the Seller will provide, at its sole discretion, appropriate repair or replacement of the Product without charge at a designated facility, except as stipulated in the "Warranty Exclusions" as described below. However, if the Product is installed or integrated into the Buyer's equipment or machines, the Seller shall not reimburse the cost of removal or re-installation of the Product or other incidental costs related thereto, any loss opportunity, any profit loss or other incidental or consequential losses or damages incurred by the Buyer or its customers.

Warranty exclusion:
Notwithstanding the above warranty, the warranty as set forth herein shall not apply to any problem or damage to the Product that is caused by.

- Installation, connection, combination or integration of the Product in or to the other equipment or machine that rendered by any person or entity other than the Seller.
- Insufficient maintenance or improper operation by the Buyer or its customers such that the Product is not maintained in accordance with the maintenance manual provided or designated by the Seller.
- Improper use or operation of the Product by the Buyer or its customers that is not informed to the Seller, including, without limitation, the Buyer's or its customer's operation of the Product not in conformity with the specifications.
- Any problem or damage on any equipment or machine to which the Product is installed, connected or combined or any specifications particular to the buyer or its customers.
- Any changes, modifications, improvements or alterations to the Product or those functions that are rendered on the Product by any person or entity other than the Seller.
- Any parts in the Product that are supplied or designated by the Buyer or its customers.
- Earthquake, fire, flood, salt air, gas, lightning, acts of God or any other reasons beyond the control of the Seller.
- Normal wear and tear, or deterioration of the Product's parts, such as the cooling fan bearings.
- Any other troubles, problems or damage to the Product that are not attributable to the Seller.

Others:
The Seller will not be responsibility for the installation and removal of the inverter. Any inverter transportation cost shall be borne by both Seller and Buyer.

To inverter users:
The inverter described in this manual and User's Guide for HF-620 is used for variable-speed operation of 3-phase induction motors for general industry use.

▼ The inverter described in this manual is not designed and manufactured for use in equipment or a system used under the following conditions that will directly lead to death or injury: atomic energy control, aerospace equipment, traffic equipment, medical instrument and all kinds of safety devices. When our products are applied to the above equipment or system, be sure to consult us.

▼ Our products are manufactured under stringent quality control. However, install a safety device on the equipment side in order to prevent serious accidents or loss when our products are applied to equipment that may cause serious accidents or loss due to failure or malfunction.

▼ Do not use the inverter for any load other than 3-phase induction motors. When an explosion-proof motor is selected, pay attention to the installation environment, because the inverter is not of an explosion-proof type.

▼ Carefully read this manual and User's Guide for HF-620 before use for correct operation. Read User's Guide for HF-620 carefully also for long-term storage.

▼ Electrical work is necessary for installation of the inverter. Leave the electric work to specialists.



Power Transmission & Controls Group

Headquarter ThinkPark Tower, 1-1 Osaki 2-chome, Shinagawa-ku,

Tokyo 141-6025, Japan

https://japan.sumitomodrive.com/en-jp

No. DM2501E-1.0

EE01 Printed 2024.01